

Title: First-principles Modeling of Pulsar Emission

Date: Jun 13, 2017 11:00 AM

URL: <http://pirsa.org/17060057>

Abstract: <p>The modeling of pulsar radio and gamma-ray emission suggests that in order to interpret the observations one needs to understand the field geometry and the plasma state in the emission region. In recent years, significant progress has been achieved in understanding the magnetospheric structure in the limit of abundant plasma supply. However, the very presence of dense plasma everywhere in the magnetosphere is not obvious. Even the region where the observed emission is produced is subject to debate. To address this from first principles, we constructed global kinetic simulations of pulsar magnetospheres using relativistic Particle-in-Cell codes, which capture the physics of plasma production and particle acceleration. In this talk I will describe how plasma is produced in magnetospheres of pulsars and show that effects of general relativity are crucial for the activity of pulsars with low inclination angles. I will present modeling of high-energy lightcurves, calculated self-consistently from particle motion in the pulsar magnetosphere. I will also show evidence that observed radio emission is powered by non-stationary discharge at the polar cap. Finally, I will argue that giant radio pulses in the Crab are produced by coherent plasma currents, which appear at the interfaces of merging plasmoids in the current sheet beyond the light cylinder.</p>

# How do pulsars shine?

*Sasha Philippov (Princeton University)*

*Collaborators: Anatoly Spitkovsky (Princeton), Benoit Cerutti (CNRS), Sasha Tchekhovskoy (Berkeley->Northwestern U), Dmitry Uzdensky (IAS and U of Colorado)*

*Supported by NASA-ESSF and Princeton Jacobus Fellowships*

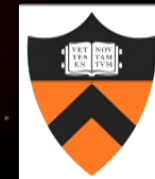

# What is a pulsar?

Pair cascade in the polar caps

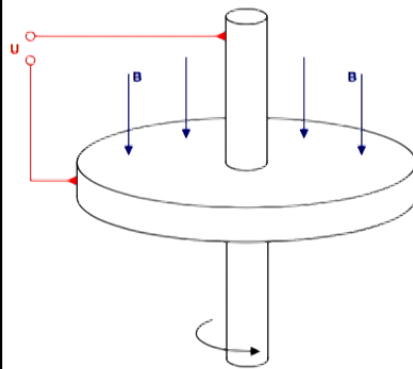
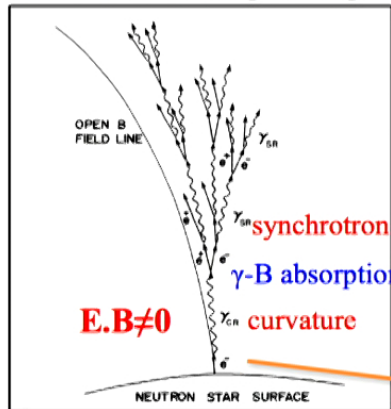

Unipolar induction

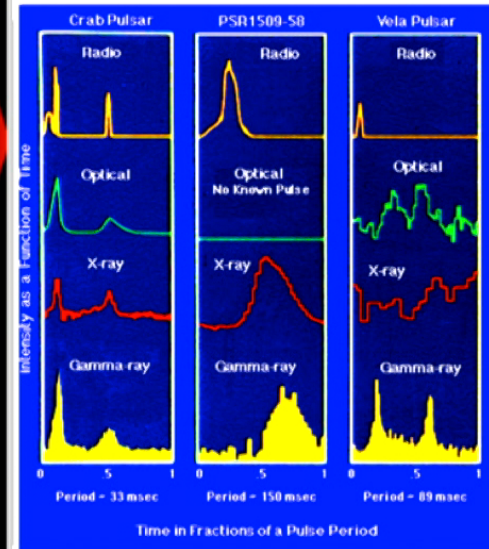
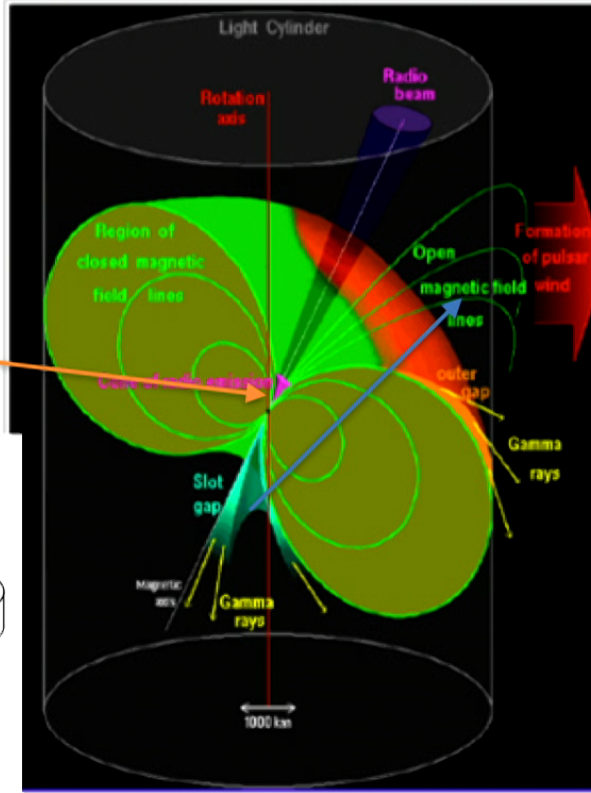

# Open questions:

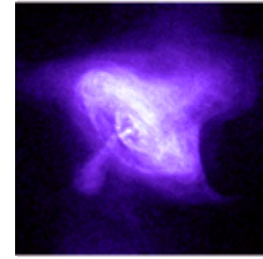

- How pulsar magnetosphere works?
  - Nebula observations favor plasma-filled magnetospheres
- How particle acceleration works?
- How pulsars shine?
  - Most of the observable energy comes in gamma-rays
- How pulsars evolve?

# Magnetospheric cartoon

$$\rho_{GJ} = -\frac{\vec{\Omega} \cdot \vec{B}}{2\pi c}$$

- Corotation electric field
- Sweepback of B field due to poloidal current
- $E \times B \rightarrow$  Poynting flux
- Electromagnetic energy loss

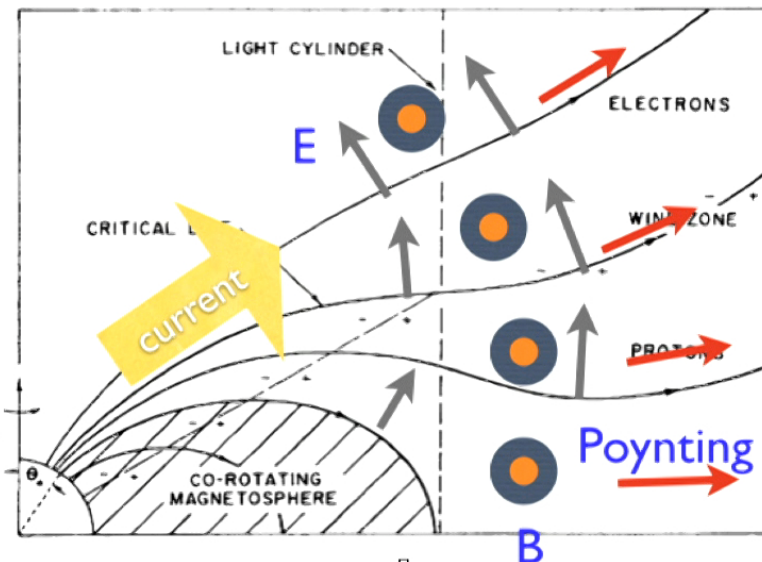

Goldreich & Julian, 1969

# Standard pulsar

- Force-free paradigm

$$\mathbf{j} = \frac{c}{4\pi} \nabla \cdot \mathbf{E} \frac{\mathbf{E} \times \mathbf{B}}{B^2} + \frac{c}{4\pi} \frac{(\mathbf{B} \cdot \nabla \times \mathbf{B} - \mathbf{E} \cdot \nabla \times \mathbf{E}) \mathbf{B}}{B^2}$$

$$\rho_c \mathbf{E} + \mathbf{j} \times \mathbf{B} = \frac{d(\cancel{\gamma \rho_p \mathbf{v}})}{dt} + \cancel{\text{pressure}}$$

$$\mathbf{E} \cdot \mathbf{B} = 0$$

$$\frac{1}{c} \frac{\partial \mathbf{E}}{\partial t} = \nabla \times \mathbf{B} - \frac{4\pi}{c} \mathbf{j}, \quad \frac{1}{c} \frac{\partial \mathbf{B}}{\partial t} = -\nabla \times \mathbf{E}$$

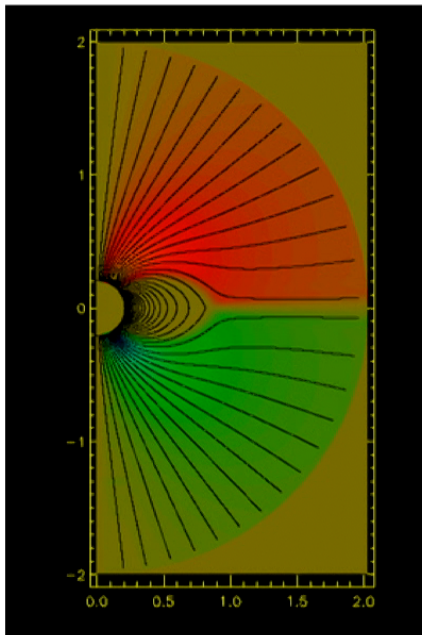

(from Spitkovsky 2006)

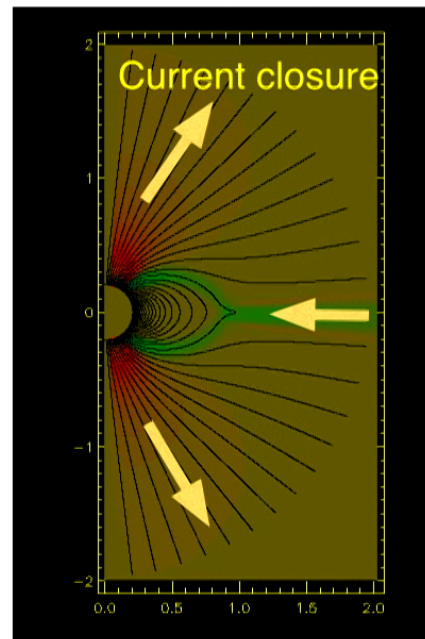

Sasha Philippov

- Y-point
- Closed/open field lines
- Current sheet
- No pathologies at null surface and LC
- Field lines are radial

# Standard pulsar

- Force-free paradigm

$$\mathbf{j} = \frac{c}{4\pi} \nabla \cdot \mathbf{E} \frac{\mathbf{E} \times \mathbf{B}}{B^2} + \frac{c}{4\pi} \frac{(\mathbf{B} \cdot \nabla \times \mathbf{B} - \mathbf{E} \cdot \nabla \times \mathbf{E}) \mathbf{B}}{B^2}$$

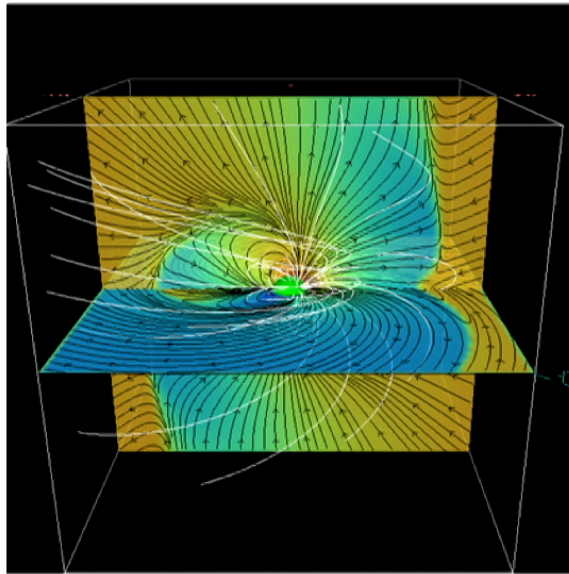

Oblique: Spitkovsky (2006), Kalapotharakos et al (2009), Petri (2012), Tchekhovskoy et al. (2014) (full MHD)

Sasha Philippov

$$\rho_c \mathbf{E} + \mathbf{j} \times \mathbf{B} = \frac{d(\cancel{\gamma \rho_m \mathbf{v}})}{dt} + \cancel{\text{pressure}}$$

$$\mathbf{E} \cdot \mathbf{B} = 0$$

$$\frac{1}{c} \frac{\partial \mathbf{E}}{\partial t} = \nabla \times \mathbf{B} - \frac{4\pi}{c} \mathbf{j}, \quad \frac{1}{c} \frac{\partial \mathbf{B}}{\partial t} = -\nabla \times \mathbf{E}$$

- Y-point
- Closed/open field lines
- Current sheet
- No pathologies at null surface and LC
- Predicts the spindown law
- Field lines are radial

$$L_{\text{pulsar}} = k_1 \frac{\mu^2 \Omega_*^4}{c^3} (1 + k_2 \sin^2 \alpha)$$

6

# What can not be done with MHD?

- Are the solutions unique? How magnetospheric plasma is produced?
- How particles are accelerated?
- How non-thermal emission is produced?

$\rho_c$	$\mathbf{j}$	$\rho_m$	$\mathbf{T}$	Non-thermal particles	Plasma instabilities
✓	✓	✓	✓	✗	✗



# PIC simulation of magnetospheres I

- Core - EM PIC codes TRISTAN-MP (Spitkovsky 2008) and Zeltron (Cerutti et. al., 2014).

$$\begin{aligned}\partial \mathbf{E} / \partial t &= c(\nabla \times \mathbf{B}) - 4\pi \mathbf{J}, & \nabla \cdot \mathbf{E} &= 4\pi \rho, & \nabla \cdot \mathbf{B} &= 0 \\ \partial \mathbf{B} / \partial t &= -c(\nabla \times \mathbf{E}), & \frac{d}{dt} \gamma m \mathbf{v} &= q(\mathbf{E} + \frac{\mathbf{v}}{c} \times \mathbf{B})\end{aligned}$$

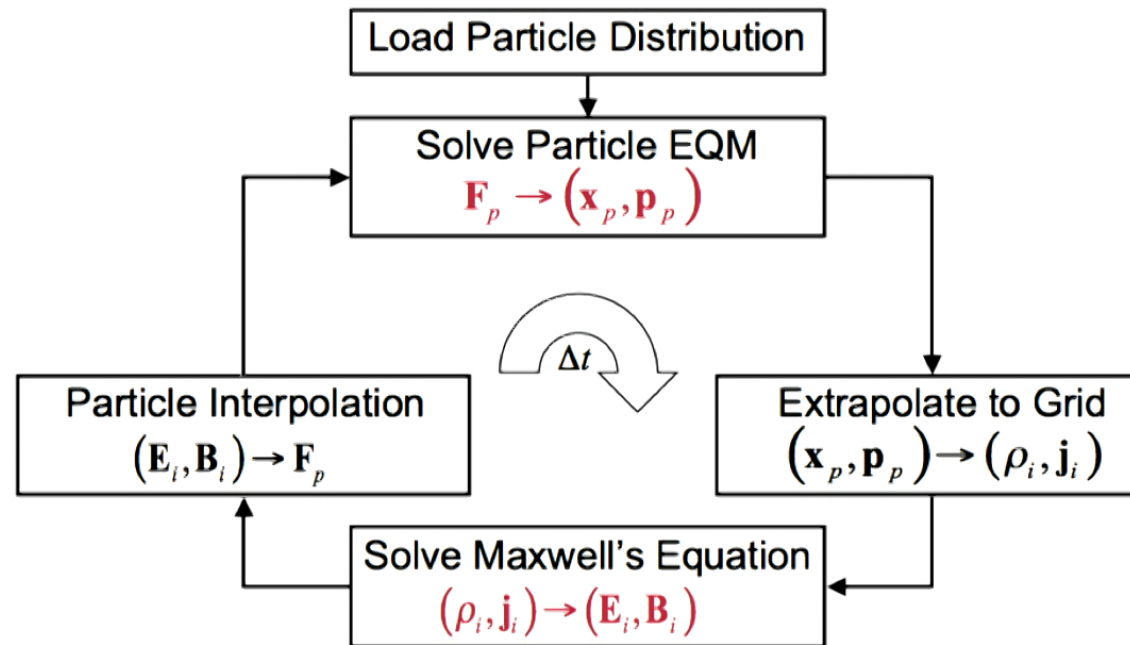

8

## PIC simulation of magnetospheres II

- Core - EM PIC codes TRISTAN-MP (Spitkovsky 2008) and Zeltron (Cerutti et. al., 2014).
- Conducting BC at the stellar surface, “absorbing layer” BC at the outer edge. Provide free escape of particles (both electrons and ions) from the surface.
- Radiative cooling is implemented for particle motion. To get correct cooling rates, need to resolve Larmor gyrations in time.
- Pair creation with the threshold based on particle energy in the inner magnetosphere. Outer magnetosphere: pair production in photon-photon collisions, do tracking of high-energy photons.
- Effects of GR: simulations in slowly rotating metric.
- Scales approached:

$$R_*/(c/\omega_p) \approx 30 - 40 \gg 1 \quad R_{LC}/R_* = 3 - 5$$

$$\Phi_{PC} = \mu\Omega^2/c^2 \approx 500 \gg \gamma_{\text{threshold}} = 40$$

9

# Jump-starting the pulsar: regimes of plasma supply

- Availability of plasma supply and whether magnetosphere is filled with plasma can determine the properties of spindown and radiation. We tried:
  - Free particle escape from the surface without pair production.
  - Free particle escape with volumetric or surface injection.
  - Free escape with pair production: aligned and oblique rotators.
  - Modifications of pair supply in GR.

10

# Electrostatically trapped solution



C. Michel

- Only free escape from the surface
- Disk-dome solution
- Almost no outflow and spin-down

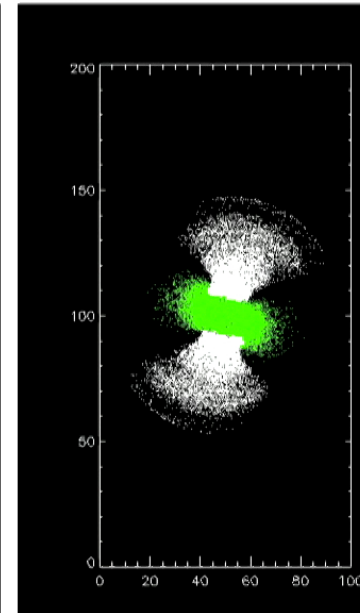
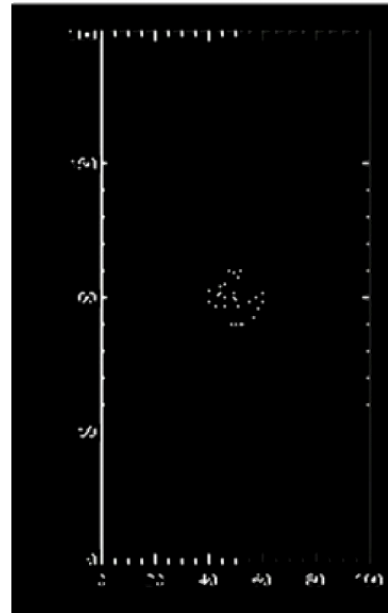

Kraus-Polstorff & Michel, 1985; Spitkovsky & Arons, 2002; Petri et al., 2002; Philippov & Spitkovsky, 2014

Sasha Philippov

11

# Electrostatically trapped solution



C. Michel

- Only free escape from the surface
- Disk-dome solution
- Almost no outflow and spin-down

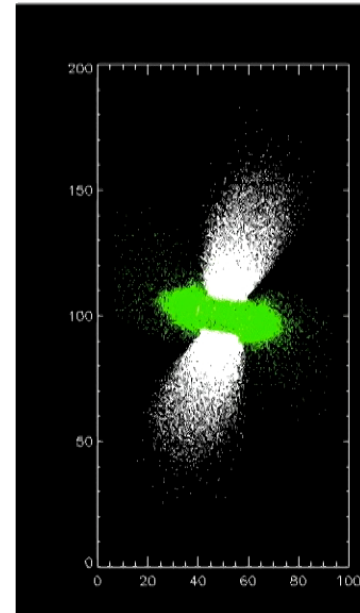
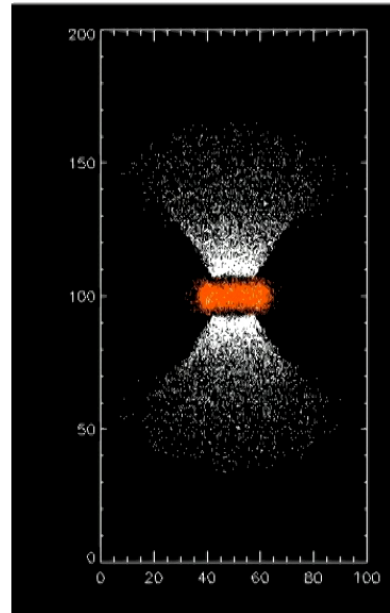

Kraus-Polstorff & Michel, 1985; Spitkovsky & Arons, 2002; Petri et al., 2002; Philippov & Spitkovsky, 2014

Sasha Philippov

11

# Extremes: plasma supply from the star

- Disk-dome solution (Kraus-Polstorff, Michel, 1985) (Spitkovsky, Arons, 2002)
- Disk is unstable to the diocotron instability
- Almost no outflow



C. Michel

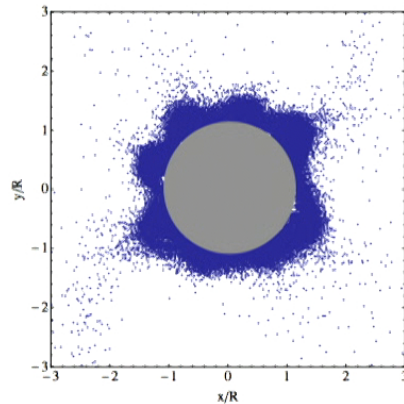

Philippov & Spitkovsky, ApJ, 2014

Sasha Philippov

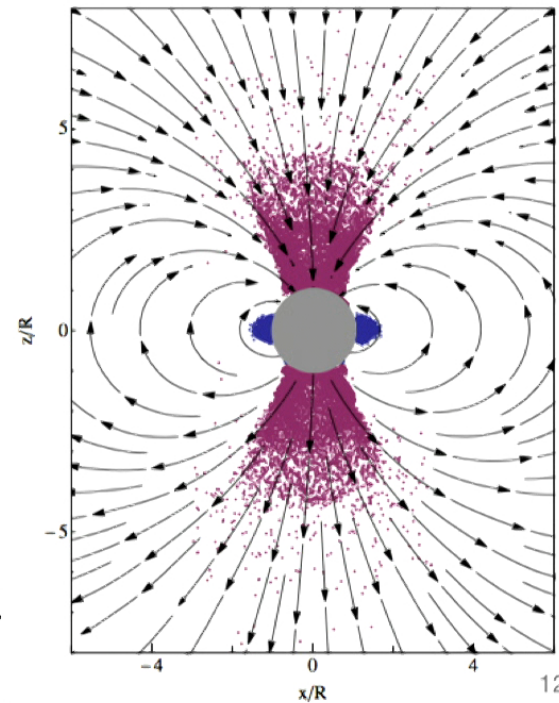

# Volumetric pair supply in the aligned magnetosphere

- Approaches force-free
- Self-consistent current sheet
- 15% of Poynting flux is dissipated within  $2R_{LC}$ .
- Observed drift-kink instability of the current sheet.
- Particles are accelerated up to  $\sigma_{LC}$  energies.

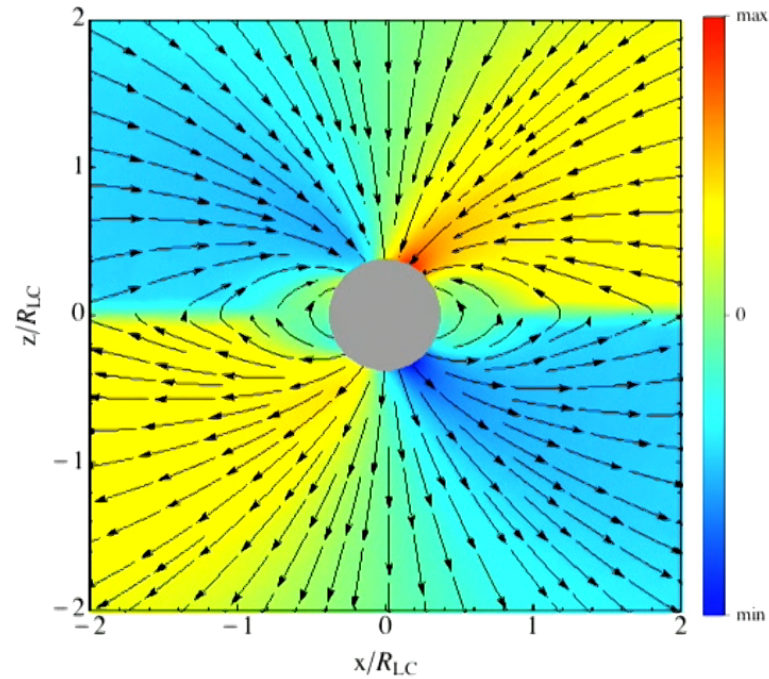

Philippov & Spitkovsky, ApJ, 2014

Sasha Philippov

13

# Volumetric pair supply in the aligned magnetosphere

- Approaches force-free
- Self-consistent current sheet
- 15% of Poynting flux is dissipated within  $2R_{LC}$ .
- Observed drift-kink instability of the current sheet.
- Particles are accelerated up to  $\sigma_{LC}$  energies.

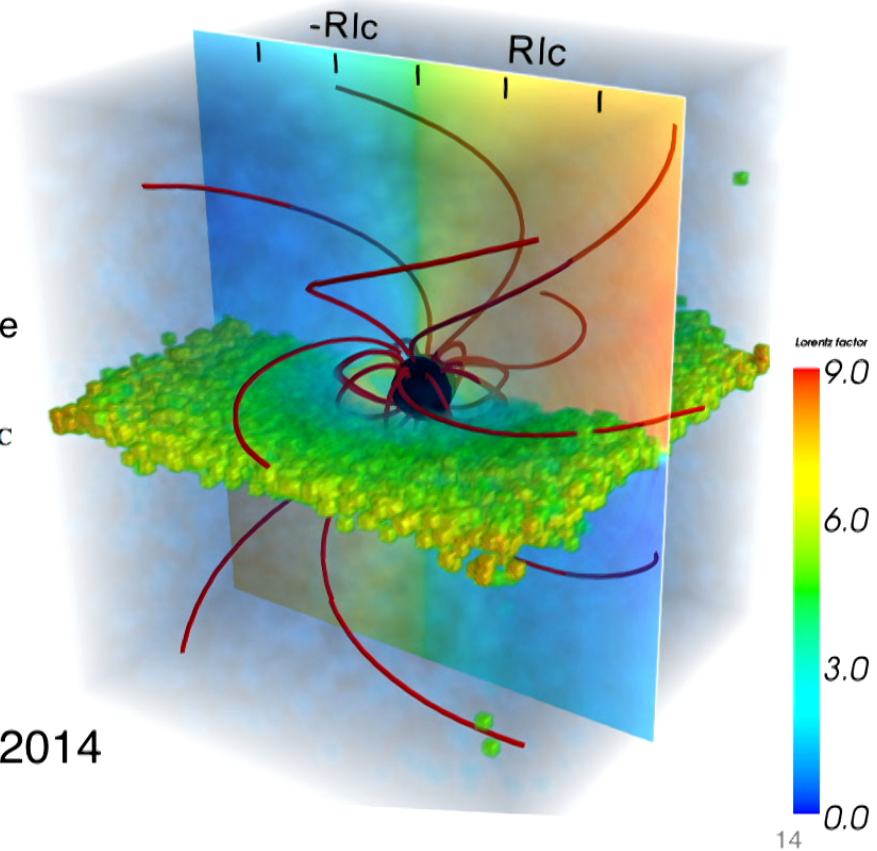

Philippov & Spitkovsky, ApJ, 2014

Sasha Philippov



# Magnetosphere is a self-regulated system

Global simulations which capture discharge physics are required!

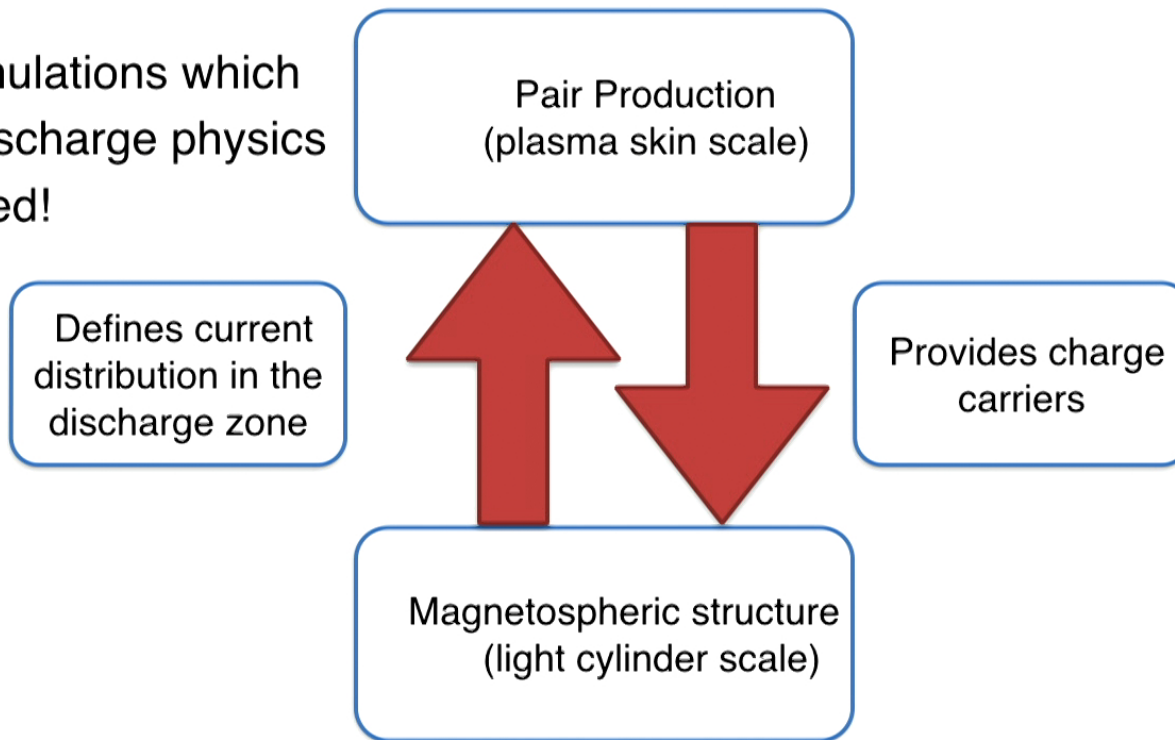

Sasha Philippov

15

# Aligned pulsar with pair production

Approaches force-free like solution, but no pair production in the polar region, where the space-charge limited flow does not lead to particle acceleration. Outer magnetosphere pair production is required to drive an active circuit.

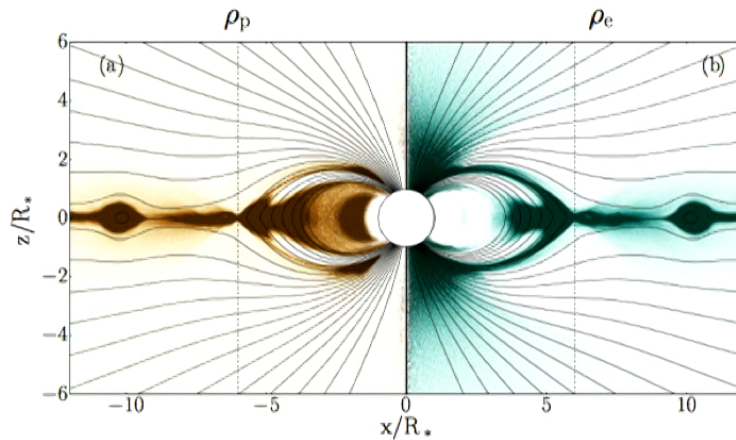

Chen, Beloborodov, ApJ, 2014

Philippov et al., ApJ, 2015

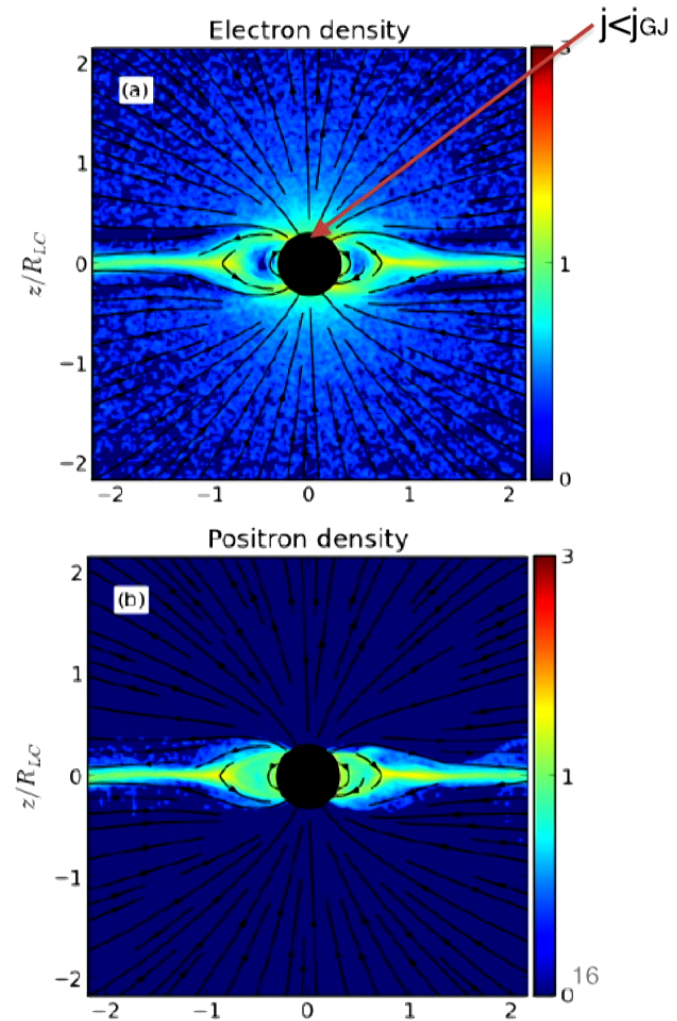

# Oblique pulsar with pair production

Philippov et al., ApJ, 2015

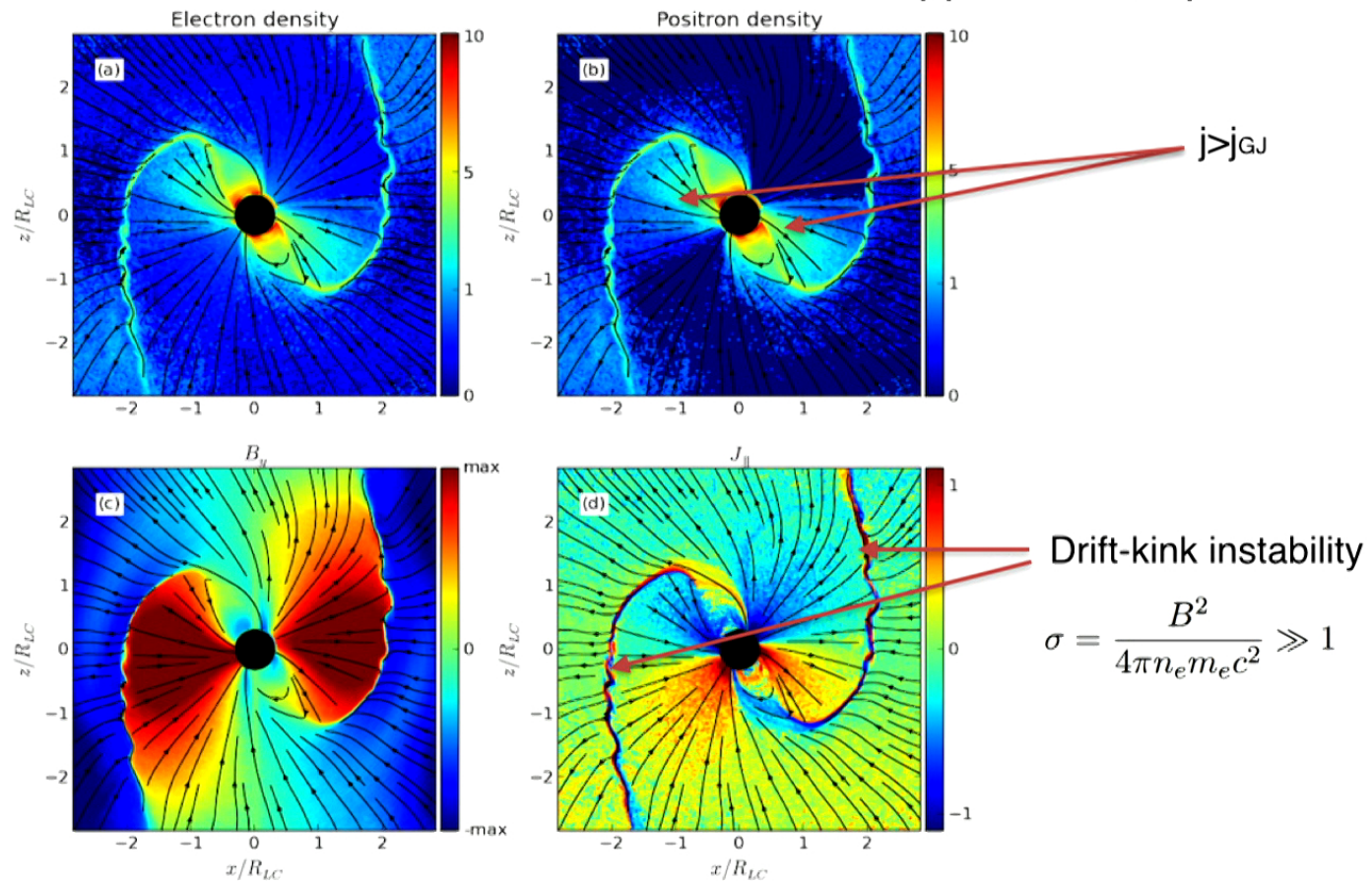

17

# Equatorial plane

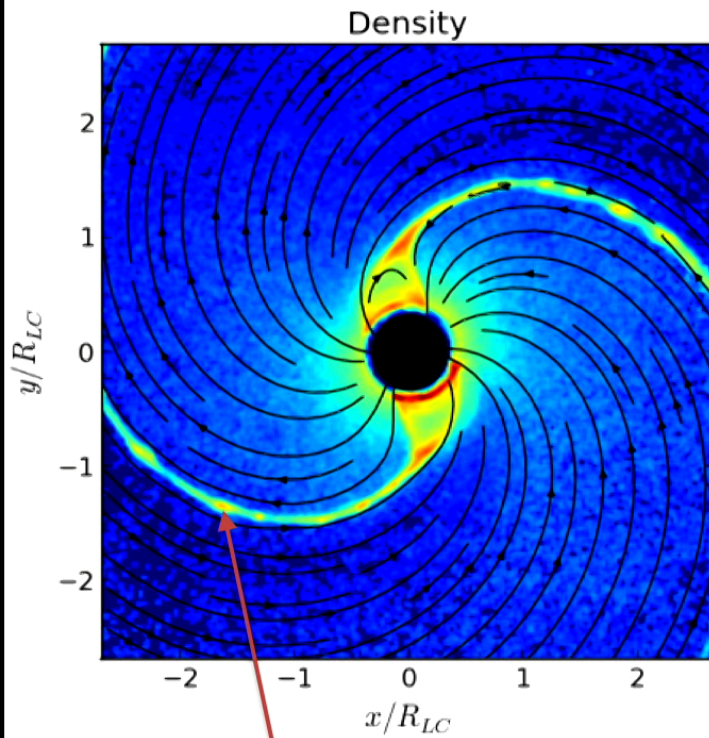

Plasmoid instability develops

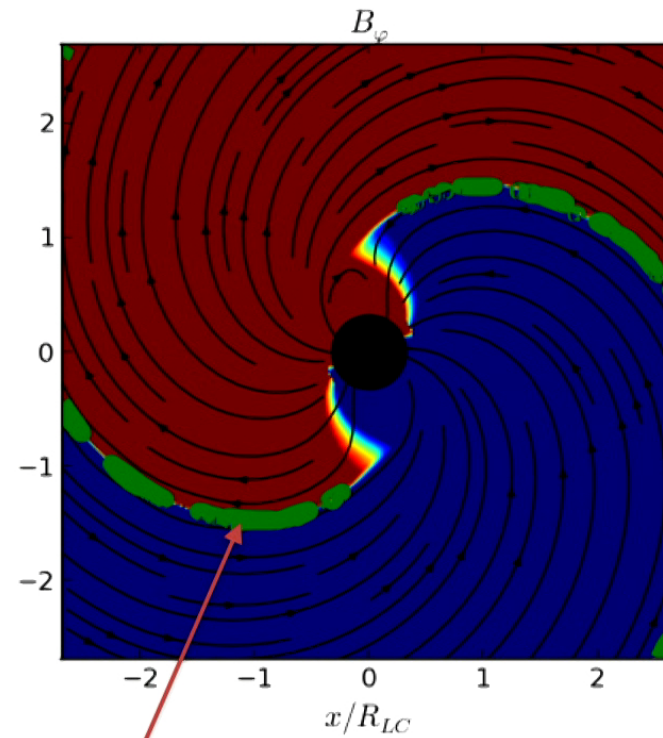

$E > B$  regions are confined to the current sheet

Sasha Philippov, TAC 2016

18

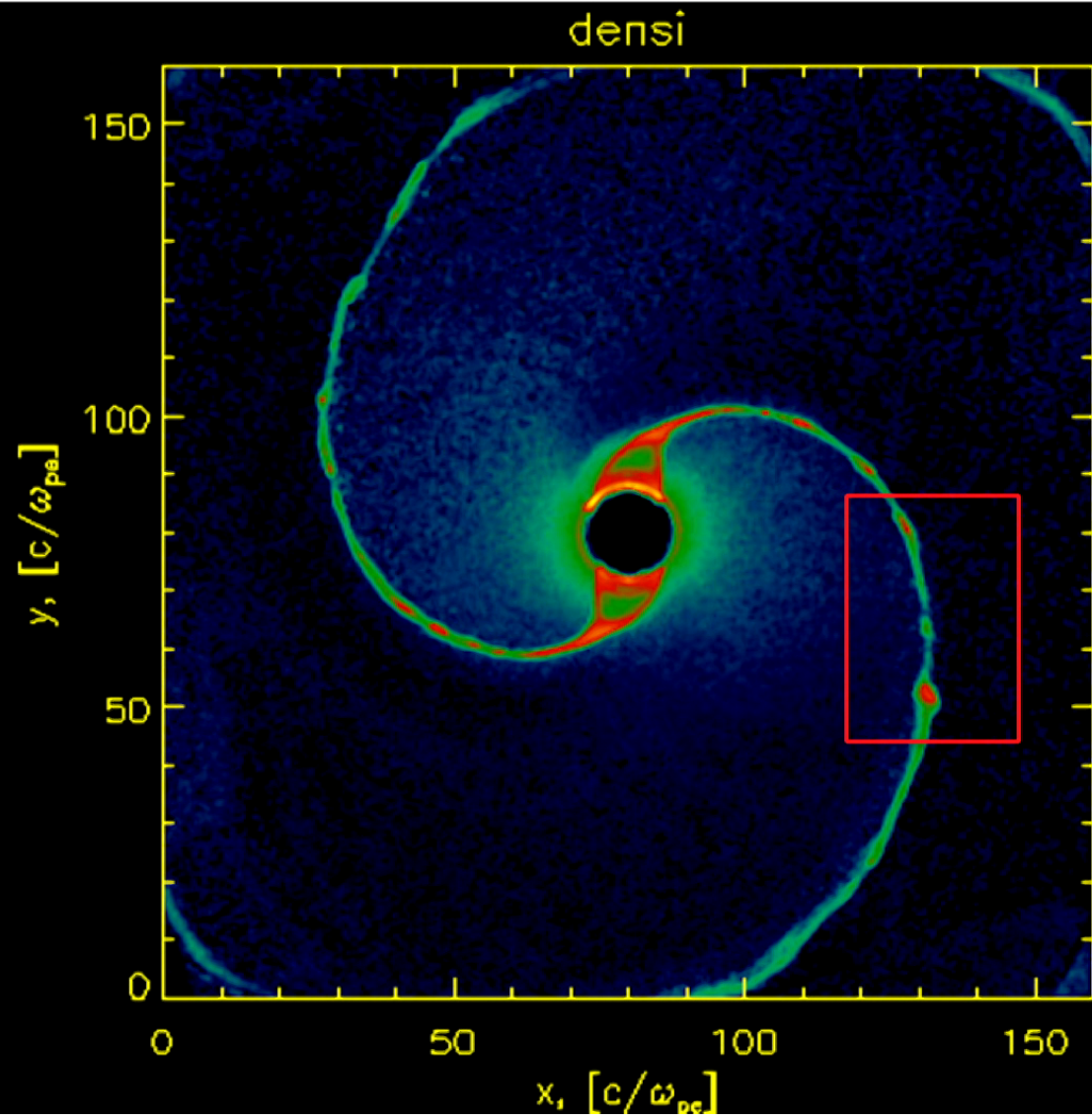
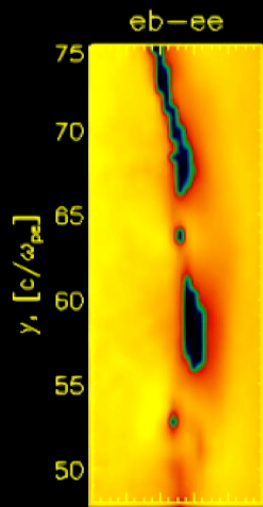
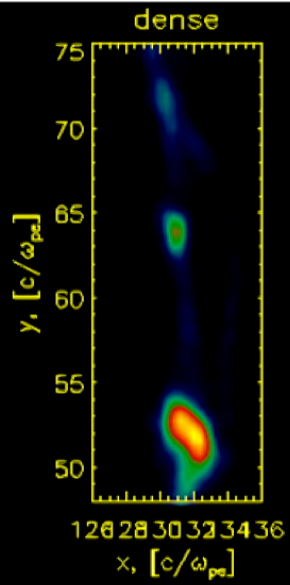

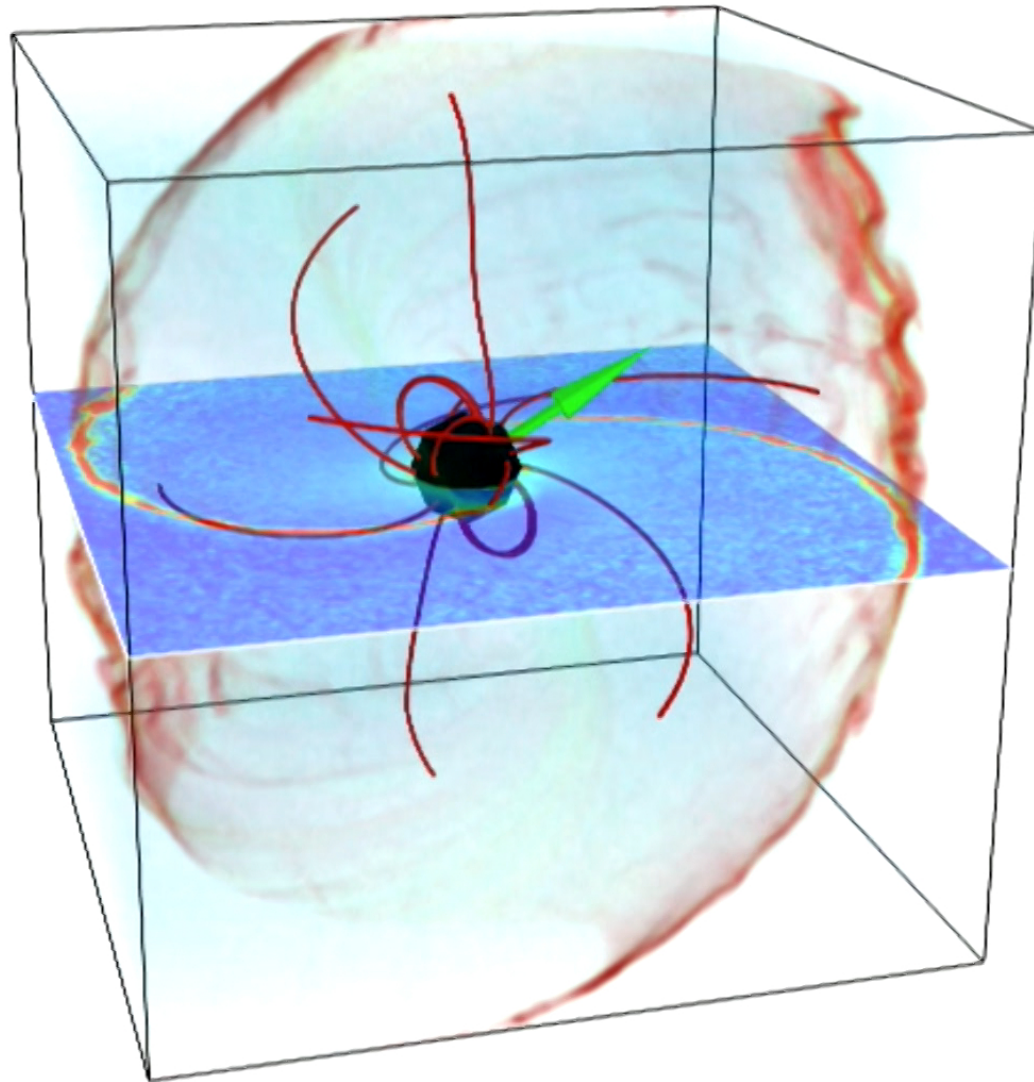

# Discharge operation

- Need to sustain both charge and current density. Key quantity is  $j/c\rho_{\text{GJ}}$
- If  $j < \text{charge density} \cdot c$ , charges are advected with non-relativistic velocity
- Current is set by twist of the field lines at LC

When realistic currents set by global magnetosphere are included in the simulation of polar cap discharge, we find that abundant pair production may not happen for most pulsars! Is this possible?

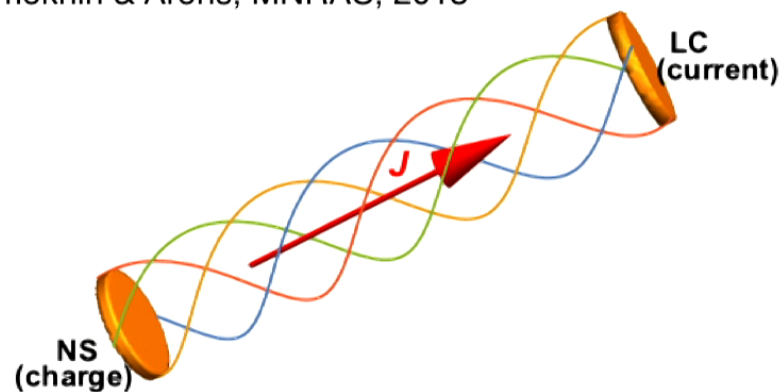
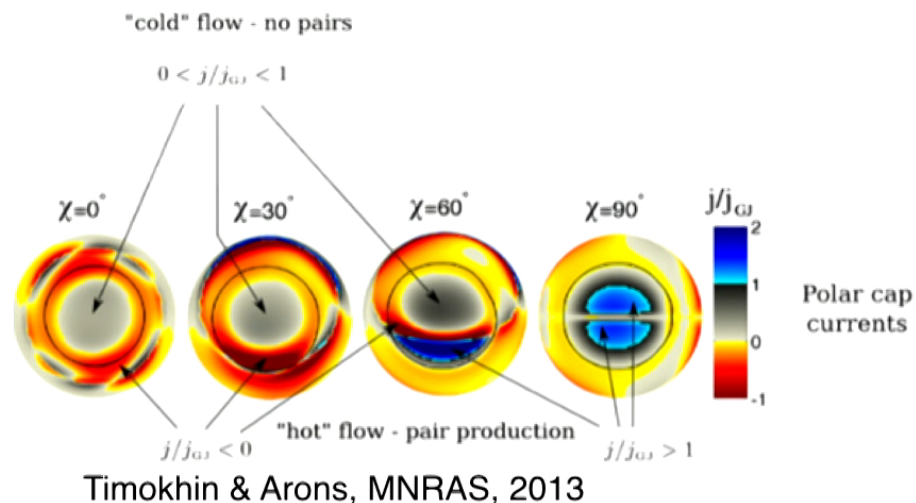

Sasha Philippov

21

# Prof. Einstein saves the day (1915-2015)!

Problem:  
High multiplicity solutions possible only for high inclinations, but radio is observed from pulsars of all obliquities.

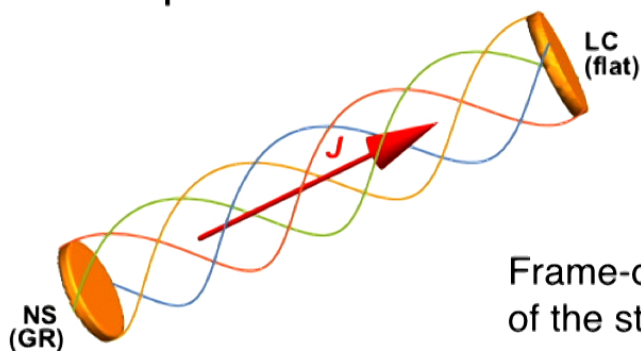

$$\frac{J_{\hat{r}}}{\rho_{GJC}} \approx \left( \frac{J_{\hat{r}}}{\rho_{GJC}} \right)_{\text{flat}} \frac{1}{1 - \omega_{LT}/\Omega_{*}}$$

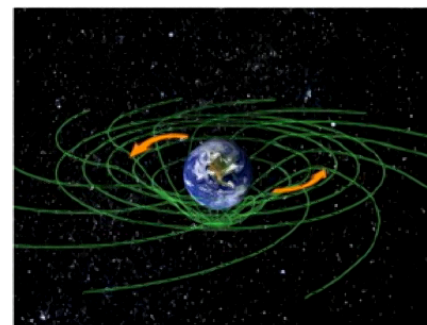

Lense-Thirring frame dragging

$$\omega_{LT} = \frac{2}{5} \Omega_{*} \frac{r_s}{R_{*}}$$

$$\nabla \times \left( \alpha \vec{E} + \frac{\vec{\beta}}{c} \times \vec{B} \right) = -\frac{1}{c} \frac{\partial \vec{B}}{\partial t},$$

$$\nabla \times \left( \alpha \vec{B} - \frac{\vec{\beta}}{c} \times \vec{E} \right) = \frac{1}{c} \frac{\partial \vec{E}}{\partial t} + \alpha \vec{j} - \rho \vec{\beta}.$$

Frame-dragging makes effective rotation frequency of the star smaller close to the star (this lowers the necessary corotation charge), but the rotation is still the same far from the star (this keeps the current the same). Beskin 1990, Muslimov & Tsygan 1992

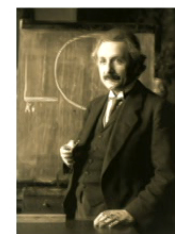



# GR aligned rotator

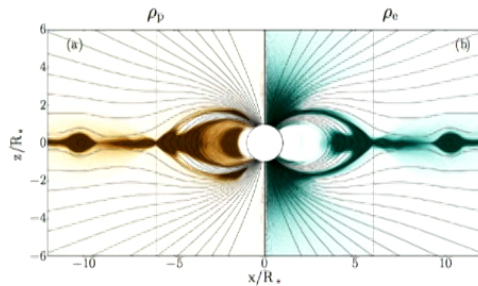
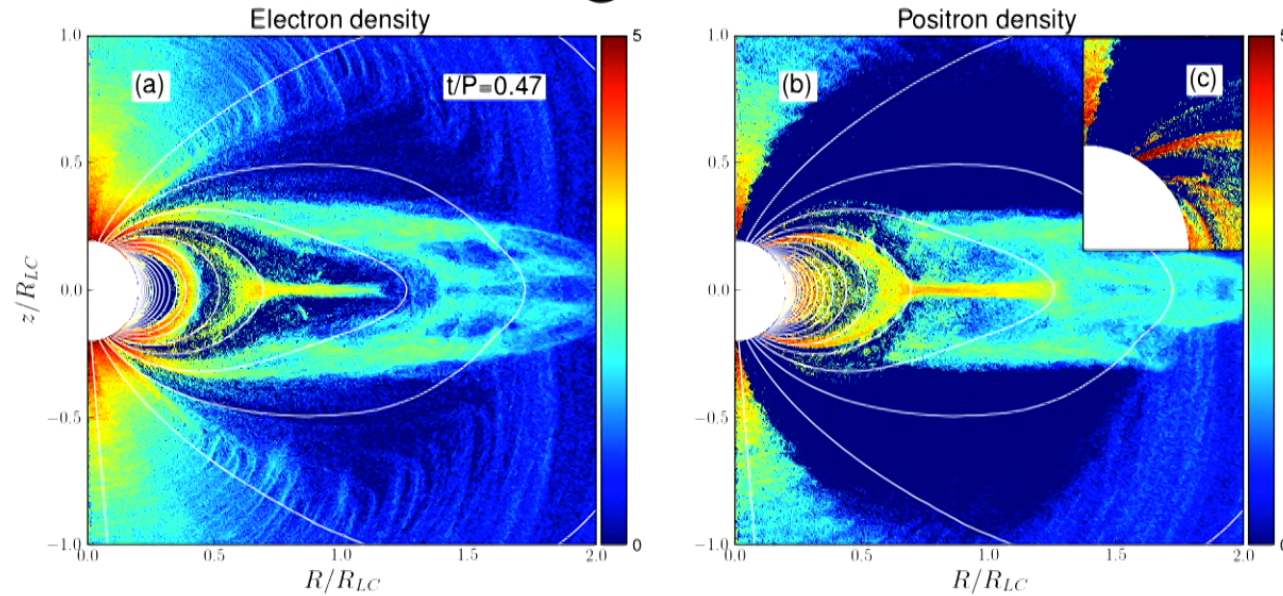

Chen & Beloborodov, ApJ, 2014

Flat space solution, no pair production

Philippov et al., 2015 ApJ

Feedback from the current sheet on  
polar cap pair production -  
implications for the radio variability?

# Implications for radio emission

- Non-stationary discharge drives waves in the open field zone.
- Waves are generated in the process of electric field screening by plasma clouds. They are driven by collective plasma motions, thus, coherent (see also Beloborodov 2008, Timokhin & Arons 2013)

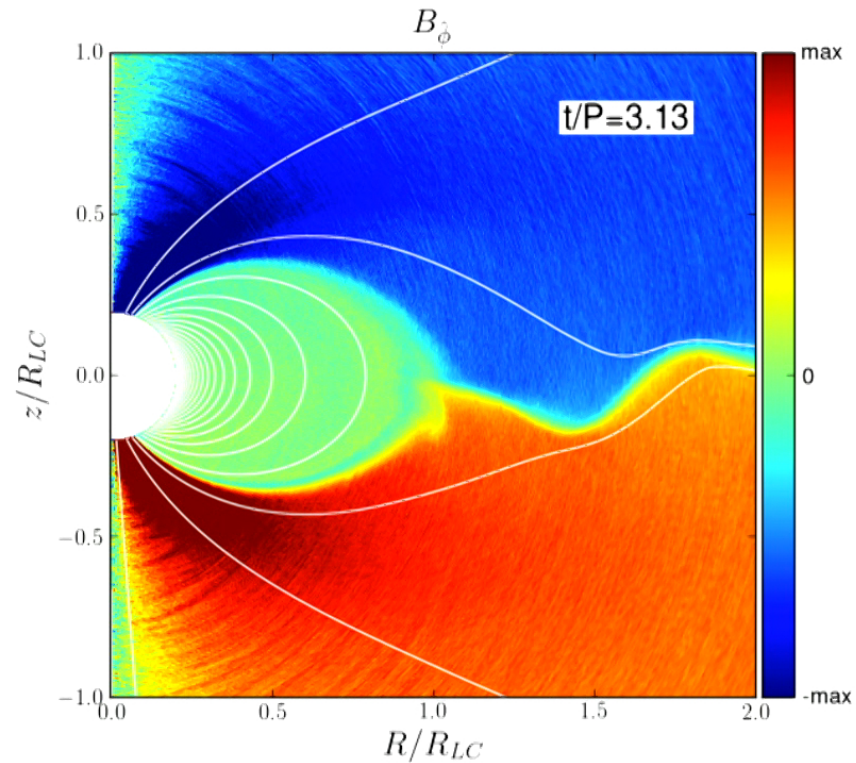

# GR oblique models: where pair formation happens?

Highlights polar cap, return current layers and the current sheet.

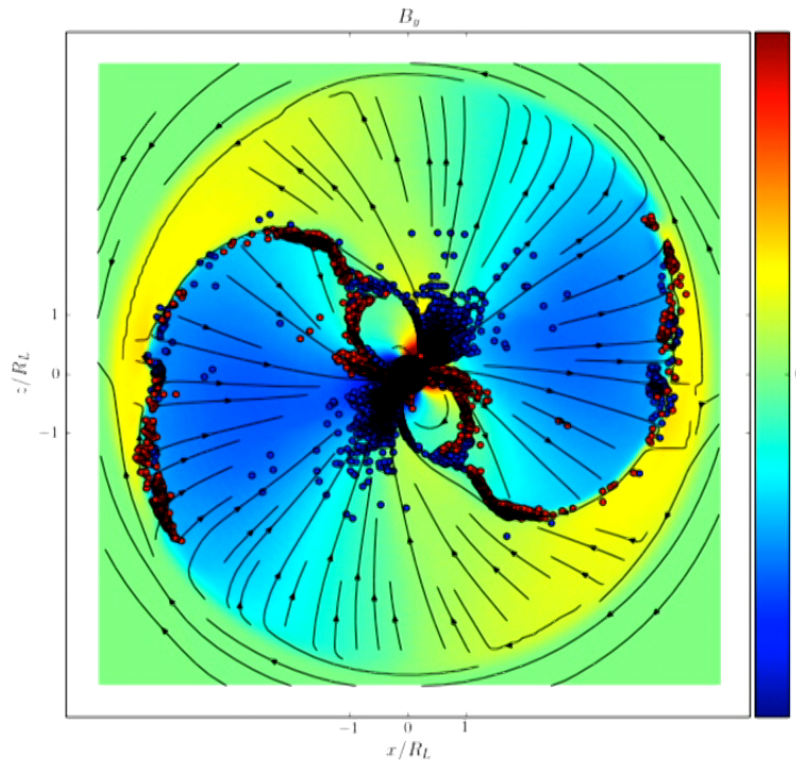

Philippov & Spitkovsky, in preparation

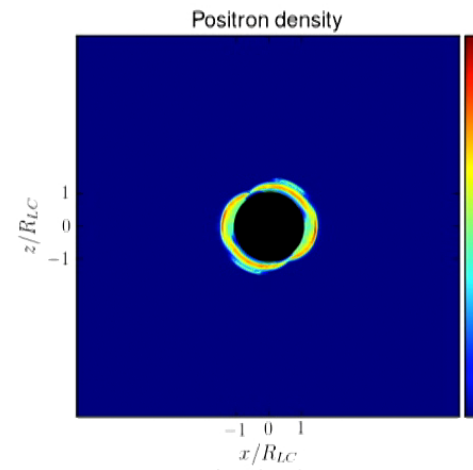
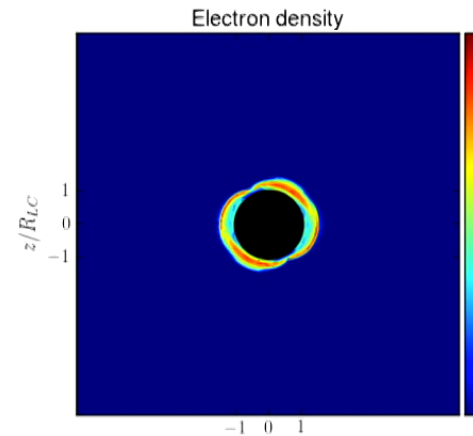

25

# GR oblique models: where pair formation happens?

Highlights polar cap, return current layers and the current sheet.

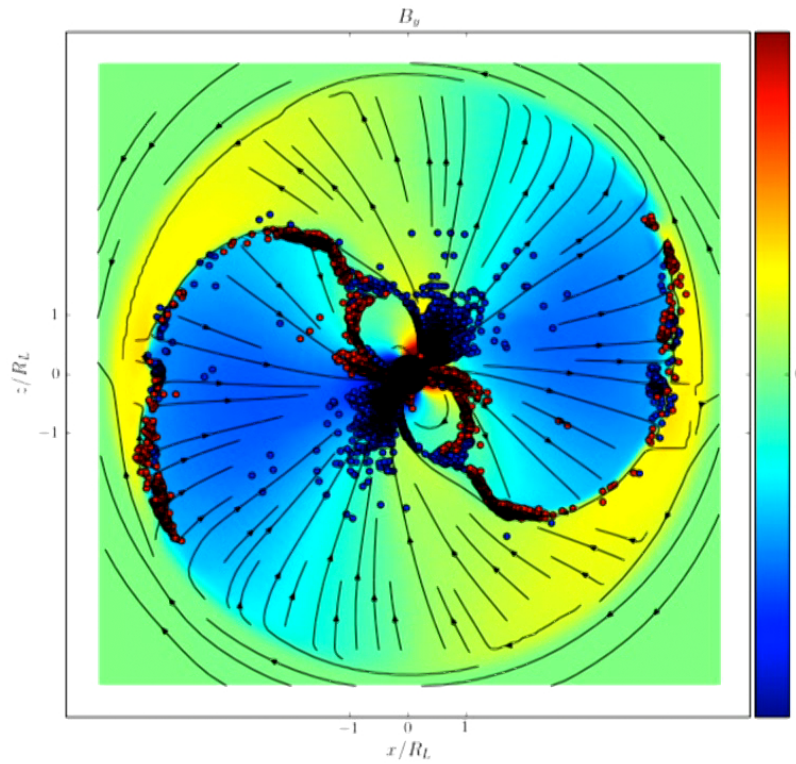

Philippov & Spitkovsky, in preparation

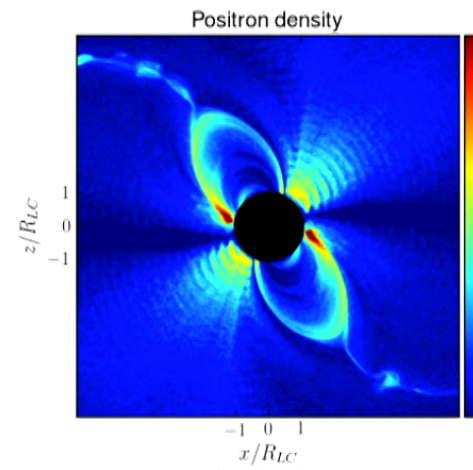
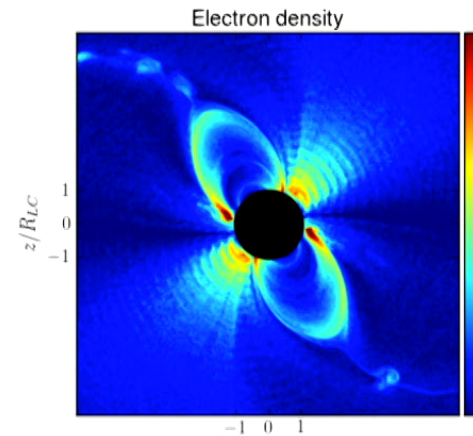

25

# Energetic ions

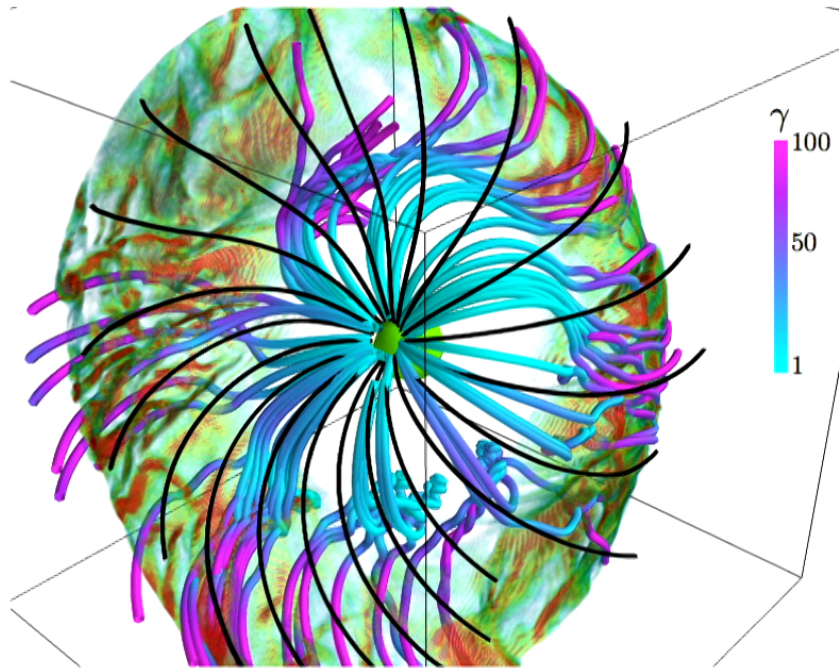

Most energetic particles that are produced in the magnetosphere are ions, extracted from the stellar surface. Gain significant fraction of the open field line voltage. Implications for UHECRs?

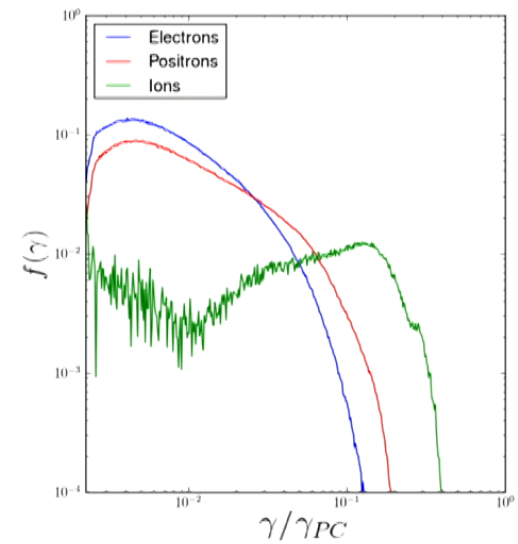

# Gamma-ray modeling

$i=30$  - Phase=0.10 - Positrons -

- Simulations prefer current sheet as a particle accelerator. Particles radiate synchrotron emission.
- We apply radiative cooling on particles and collect photons.
- Observe caustic emission.
- Neutral injection at the surface.
- Predict gamma-ray efficiencies 1-20% depending on the inclination angle. Higher inclinations are much less dissipative.

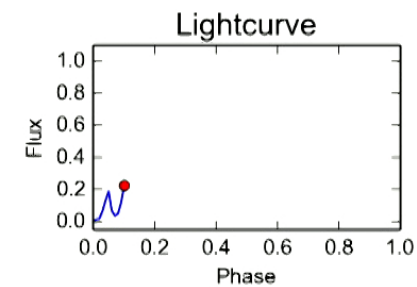
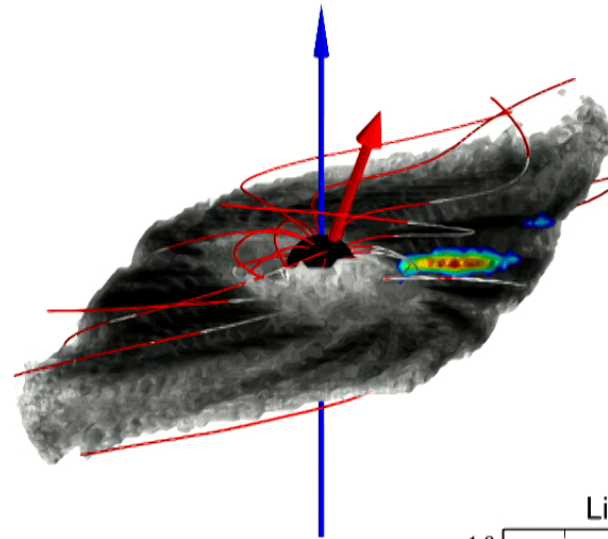

Cerutti, Philippov & Spitkovsky  
MNRAS 2016

28

# Lightcurves & spectra

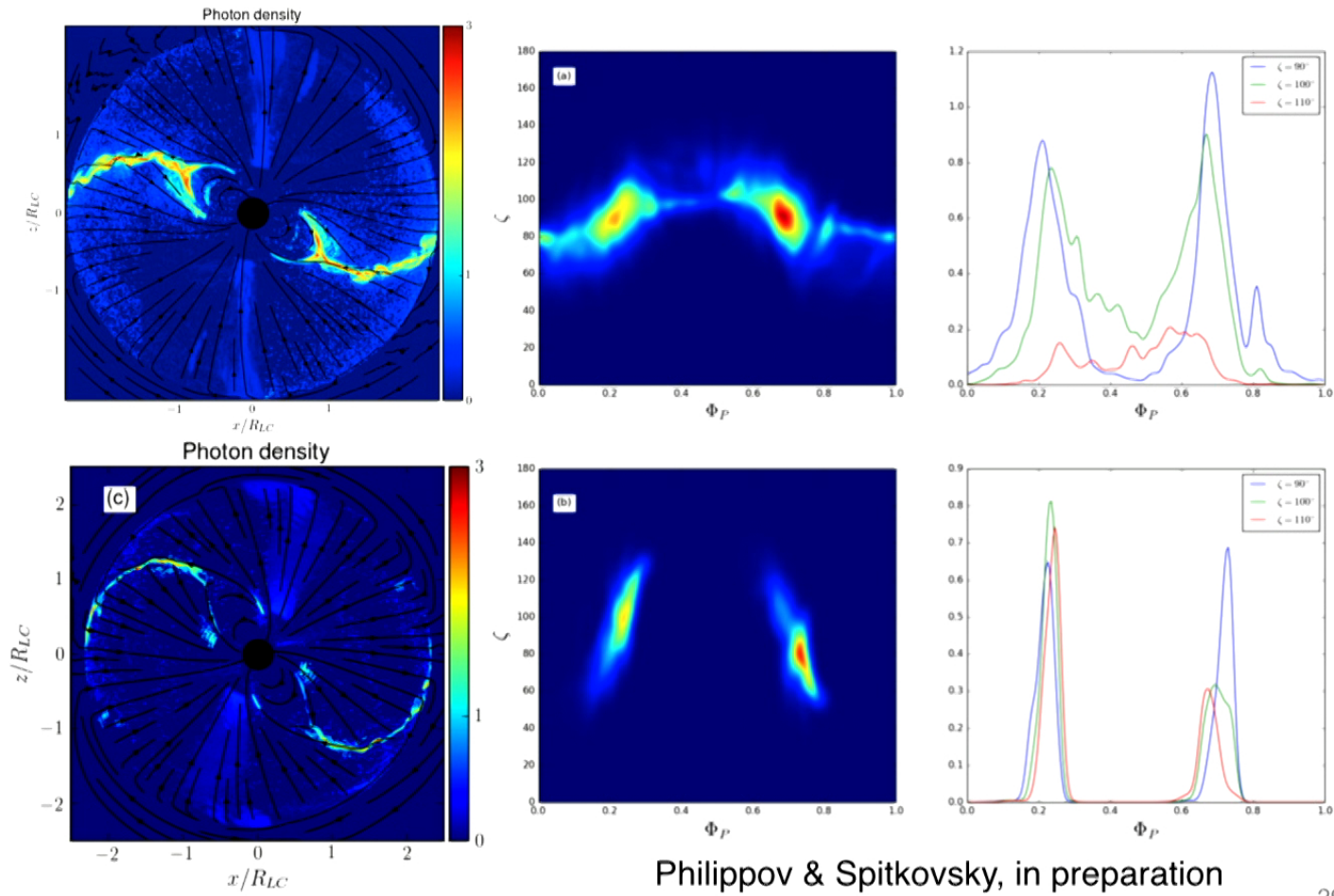

Philippov & Spitkovsky, in preparation

29

# Lightcurves & spectra

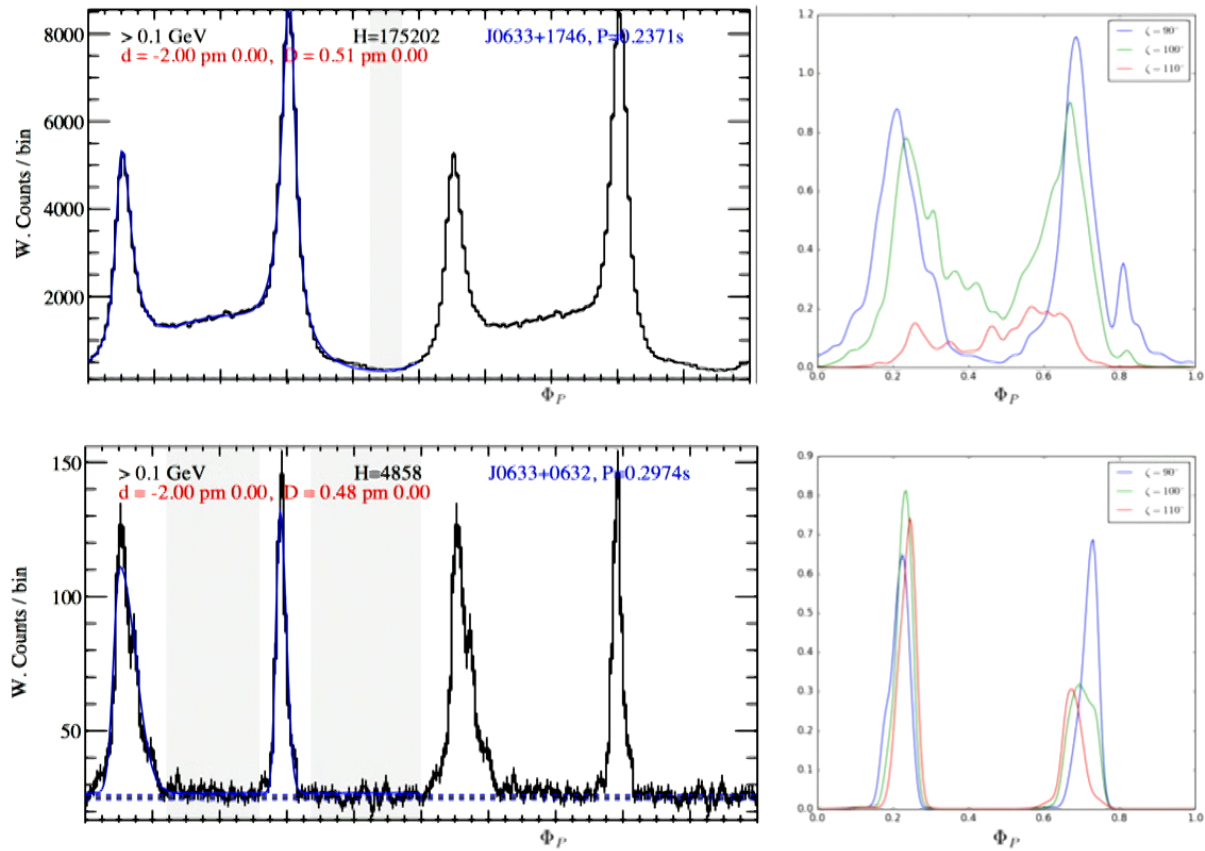

Philippov & Spitkovsky, in preparation



# Lightcurves & spectra

- Particle acceleration is not limited by synchrotron cooling.
- Easily produce photons higher than the burnoff limit.

Photon spectra

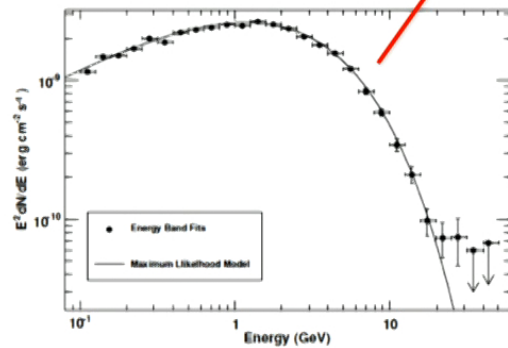
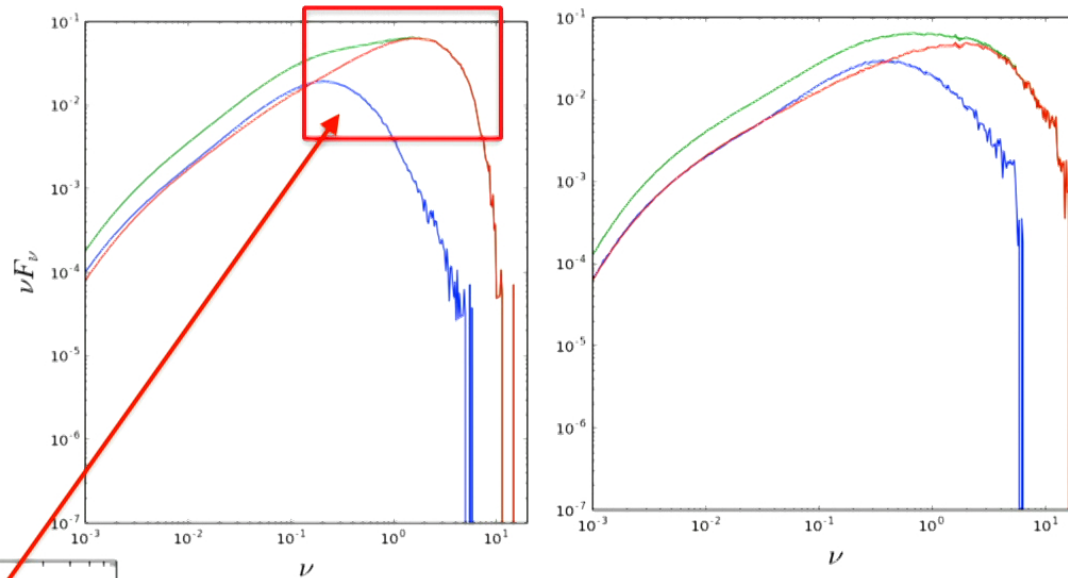

$$\nu_{\max} \approx 3e (0.1 B_{\text{LC}}) \sigma_{\text{LC}}^2 / 4\pi m_e c$$

Pair production sets the sigma parameter.

Lyubarsky 1996

Philippov & Spitkovsky, in preparation

# Giant pulses from reconnection

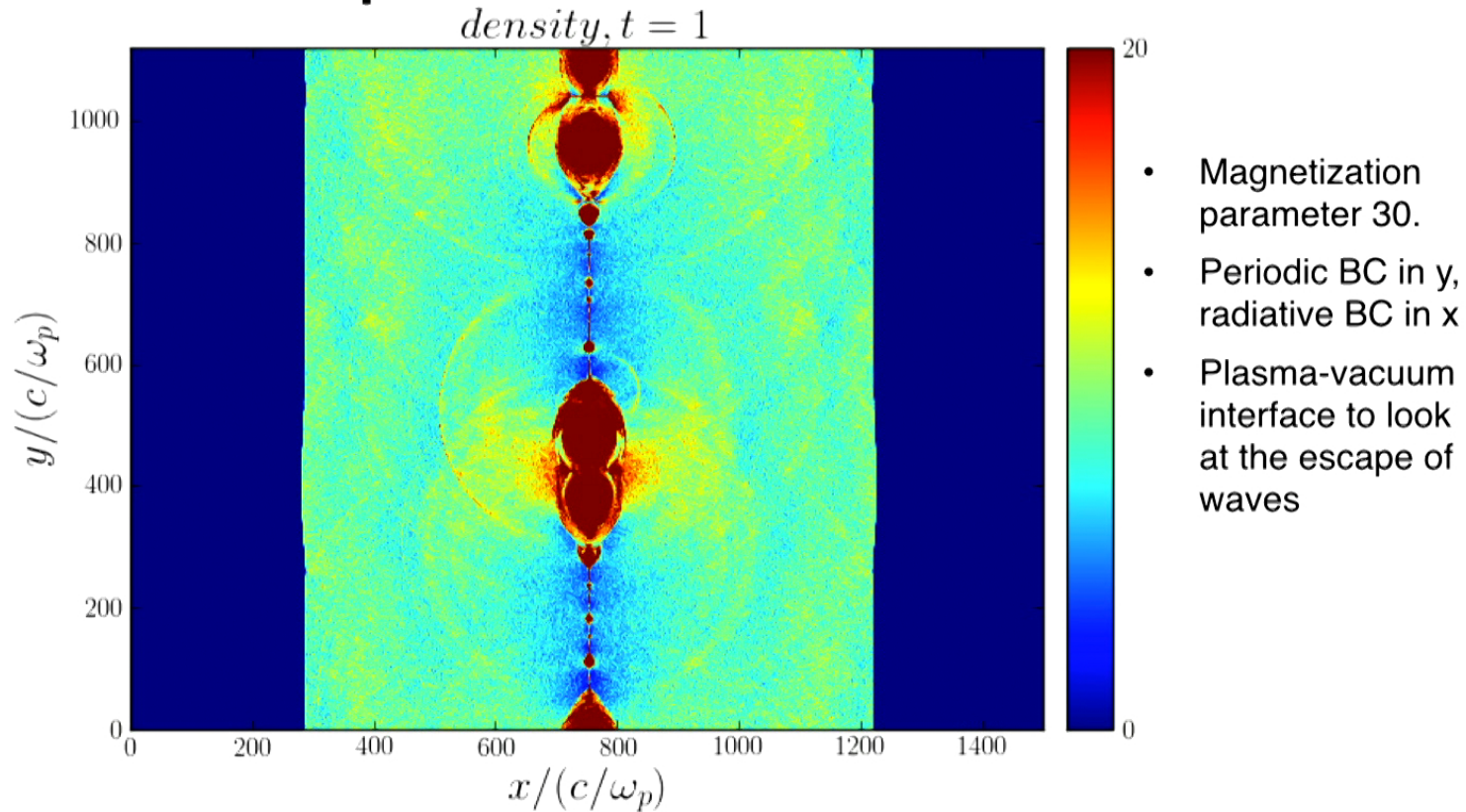

- Current sheet breaks into a plasmoid chain.
- Plasmoids merge.

How does the EM signature look like?

32

# Conclusions

- Origin of pulsar emission has been a puzzle since 1967 - full kinetic simulations are finally addressing this from first principles.
- In flat space, self-consistent kinetic models show that pair cascade does not operate in the polar region for small obliquities, works for  $>40$  degrees.
- General relativity effects are essential in producing discharges in low obliquity pulsars.
- Current sheet is an effective particle accelerator. Particles in the sheet emit powerful gamma-rays mainly via synchrotron mechanism.
- Pulsars are sources of energetic ions. UHECRs?
- Low altitude radio emission is likely caused by the non-stationary discharge at the polar cap.

35