

Title: Can Stradivariâ€™s Sound Be Measured?

Date: Mar 22, 2017 02:00 PM

URL: <http://pirsa.org/17030086>

Abstract: <p>It has long been believed that Stradivari and his contemporaries in 18th Century Italy built violins with playing qualities unmatched by later makers. However, a team of researchers led by Claudia Fritz and Joseph Curtin have shown that under double-blind conditions neither professional violinists nor experienced listeners can tell Old Italian violins from new ones at better than chance levels. Moreover, players and listeners tend to prefer the new. Violin-maker, researcher, and MacArthur Fellow Joseph Curtin will discuss recent developments in violin science, and his own interest in measuring violin sound in order to establish objective parameters for violin quality.</p>

Six widely-held beliefs about the violin



Antonio Stradivari and Guarneri del Gesu
were the greatest violin-makers who ever lived

(No known likeness of Stradivari exists)



Violins improve with time and playing.
They may even retain the "imprint" of past players



Any experienced violinist can tell a new violin from an old



Old Italian violins will out-project seemingly louder new instruments

”For centuries scientists have struggled in vain
to discover the secrets of Stradivari”

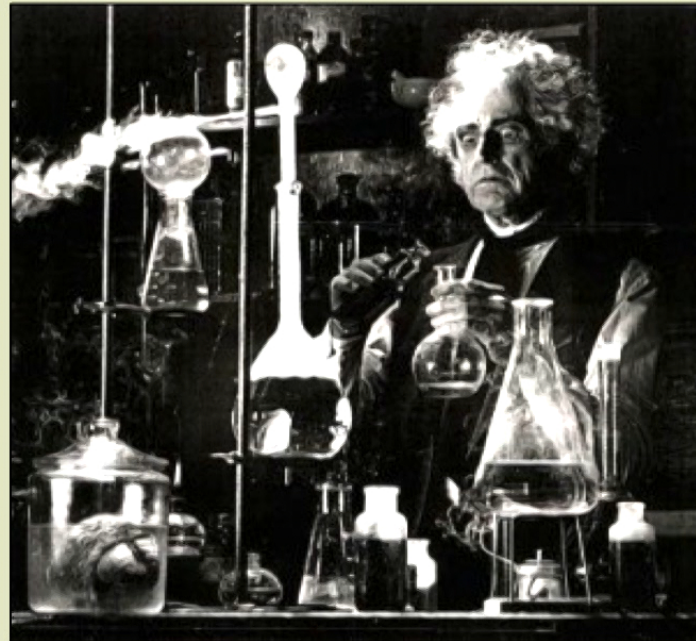



The best Old Italian violins have playing qualities that cannot be found in instruments built elsewhere and later

What evidence supports these beliefs?

Abraham Heschel

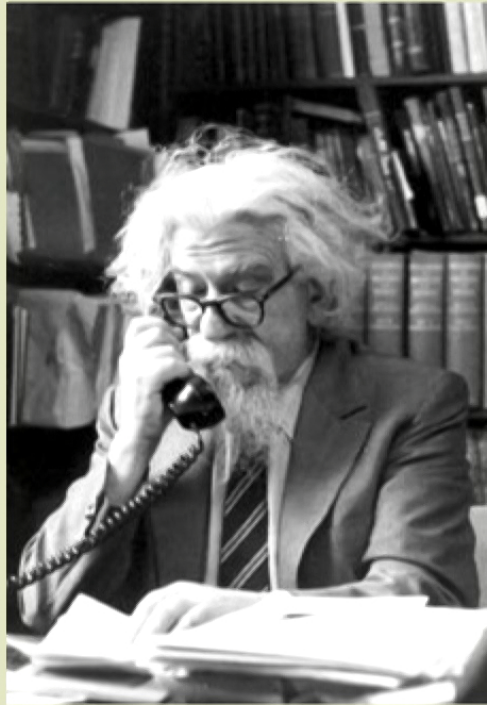

First recorded blind test: 1784



Marie Antoinette

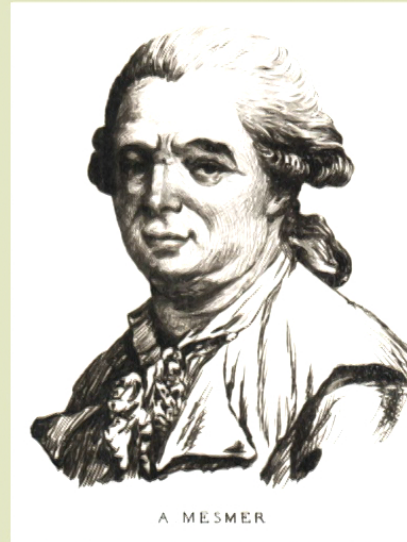

Franz Mesmer



King Louis XVI

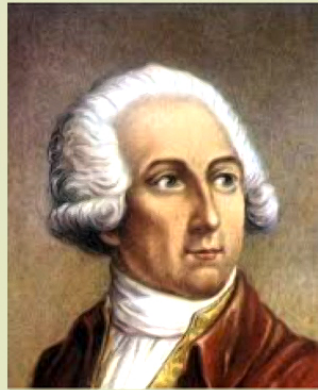

Antoine Lavoisier



Benjamin Franklin

BBC Radio blind-test from the 1970s



Player: Manoug Parikian

Jury: Pinchas Zukerman, Isaac Stern, Charles Beare.

Violins: Stradivari, Guarneri del Gesu, Vuillaume, Ronald Prail

Jury asked to guess the order in which they were played

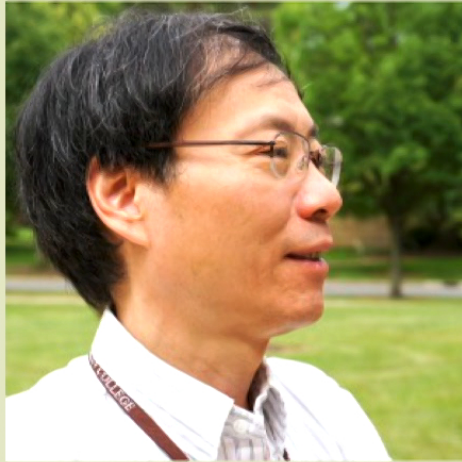

Fan-Chia Tao



Claudia Fritz

Indianapolis Experiment: “Old Violins or New: What do Players Prefer?”

PNAS, January 2012

Claudia Fritz, Joseph Curtin, Jacques Poitevineau, Palmer Morrel-Samuels, Fan-Chia Tao

- Large hotel room divided by a cloth screen
- Two Strads, one Guarneri del Gesu, and three new violins
- Players asked to choose favorites in 1-minute pair-wise comparisons
- Players given 20 minutes to play all six and select their “take-home” favorite and their least-favorite
- Players asked to rate various characteristics, and guess whether new or old

Results, in brief . . .

- Favorite violin was new
- Least favorite was a Stradivari
- Players seemed unable to tell new from old

Criticisms of Indianapolis Experiment

- Testing a Strad in a hotel room is like testing a Ferrari in a parking lot
- Too few violins
- We picked the best new violins and the worst old violins, or must have tampered with the set-up and adjustment of the old
- It takes a long time – even years – to get the best out of a Stradivari. The qualities of new violins are more immediately accessible to players



Hugues Borsarello

“Soloist evaluations of six Old Italian and six new violins”

Claudia Fritz, Joseph Curtin, Jacques Poitevineau, Hugues Borsarello,
Indiana Wollman, Fan-Chia Tao, and Thierry Ghasarossian *PNAS*, 2014



Russian soloist Ilya Kaler

- 10 renowned soloists
- 6 new violins
- 6 old violins (5 Strads)

Each soloist asked:

“choose a violin to replace your own for
an upcoming concert tour”

“Soloist evaluations of six Old Italian and six new violins”

Claudia Fritz, Joseph Curtin, Jacques Poitevineau, Hugues Borsarello,
Indiana Wollman, Fan-Chia Tao, and Thierry Ghasarossian *PNAS*, 2014



Two 75 minute sessions for each soloist

Soloists were asked to:

- Use their own violin as a reference
- Eliminate unsuitable violins
- Rank their 4 favorites in order of preference
- Guess the age of 6-8 violins

“Soloist evaluations of six Old Italian and six new violins”

Claudia Fritz, Joseph Curtin, Jacques Poitevineau, Hugues Borsarello,
Indiana Wollman, Fan-Chia Tao, and Thierry Ghasarossian *PNAS*, 2014



- Session 1 in a rehearsal room
- Session 2 in a concert hall
- pianist available
- Could ask for feedback from a designated listener.
- Free to test in any way they wanted.
- Encouraged to compare test violins with their own instrument
- Session 3 with orchestra & audience to assess projection

Can soloists tell whether a violin is new or old?

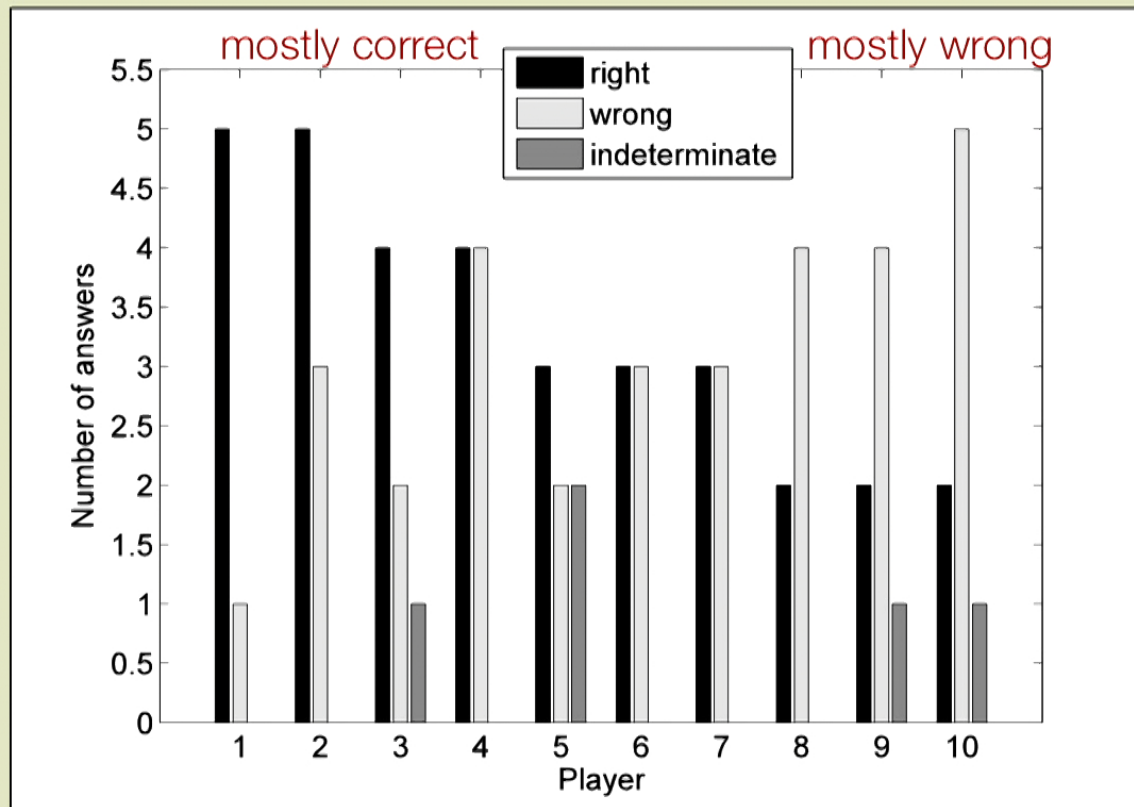

Soloist's guesses about each violin

Number of right and wrong guesses



	Correct	Wrong
New violins	15	18
Old violins	18	17

Soloists did not guess at better than chance levels

Old or new – can the audience tell?



39 listeners guessed whether seven soloists were using a new or old violins

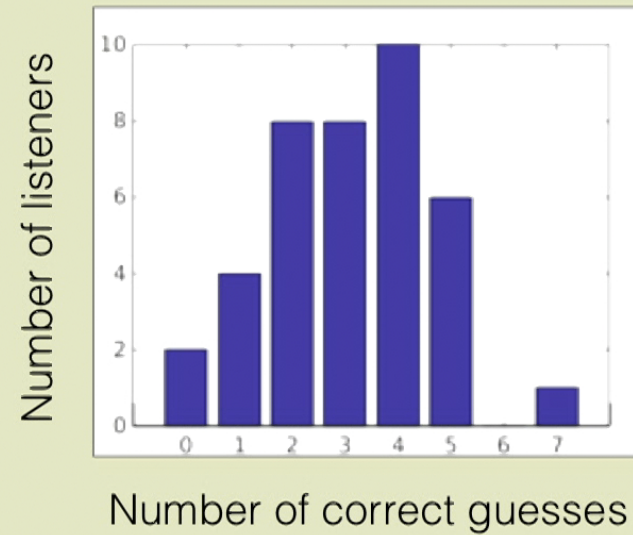

The question becomes . . .



Why are violins so hard to tell apart ?

The violin is often described as the instrument closest to the human voice . . .



Yehudi Menuhin



Maria Callas

. . . and we're really good at telling voices apart.

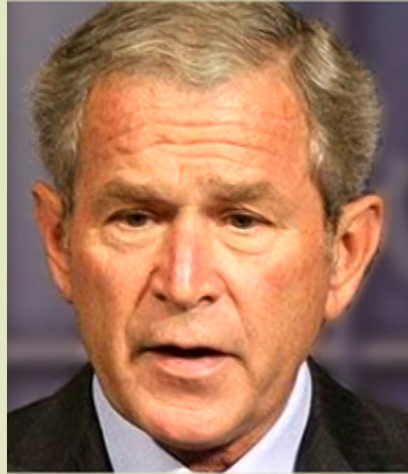

Imagine each of these men saying
“God bless America!”

Most musical instruments consist of
an oscillator that drives a resonator

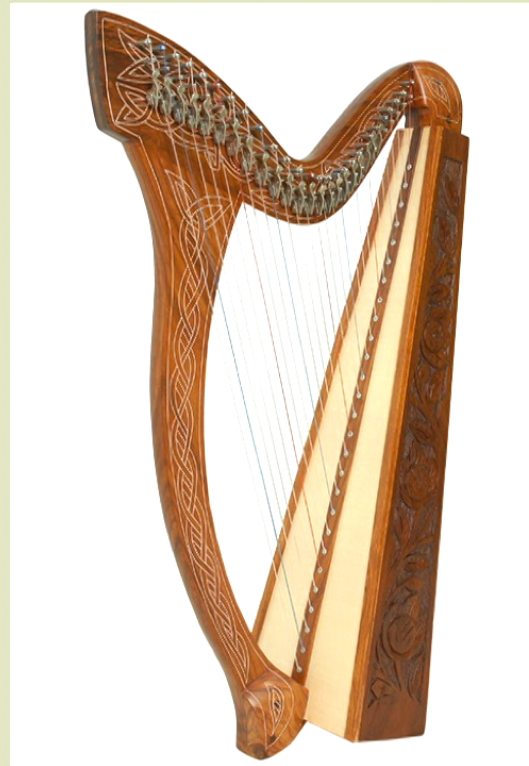

Two oscillators

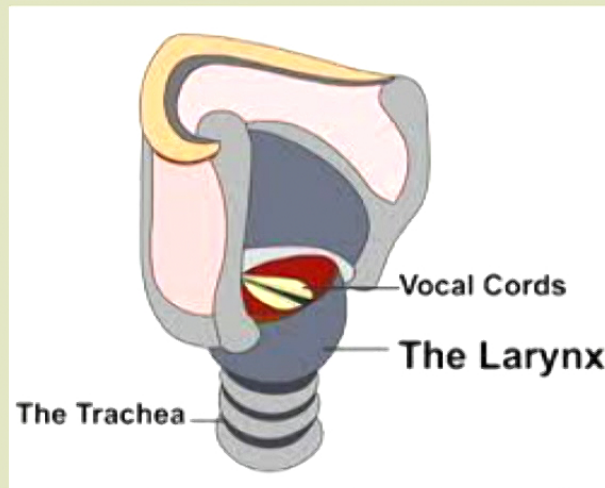

larynx

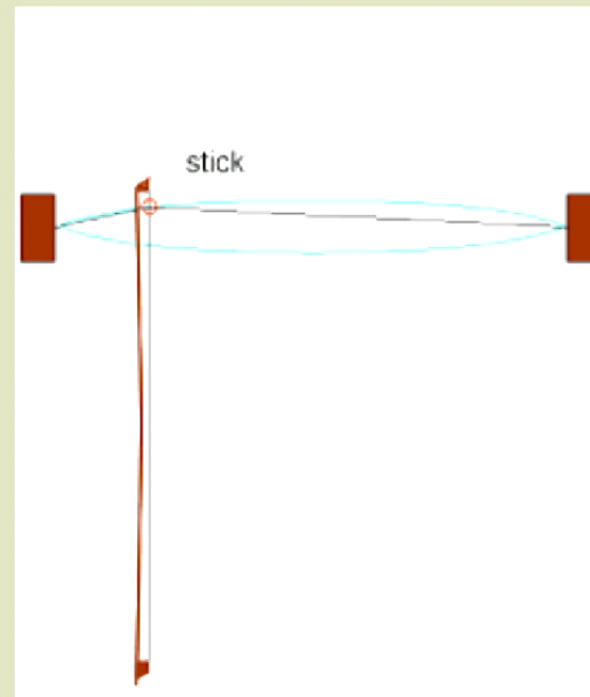

bowed string

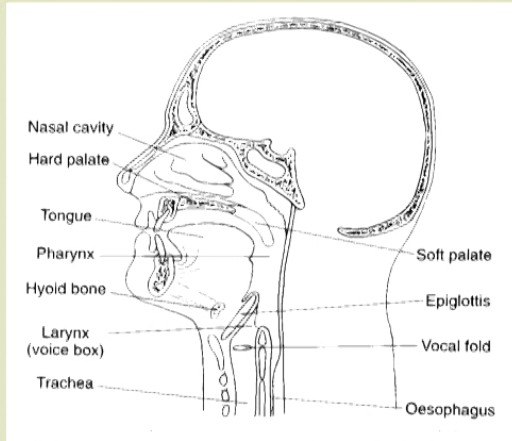

Vocal tract resonances are highly malleable

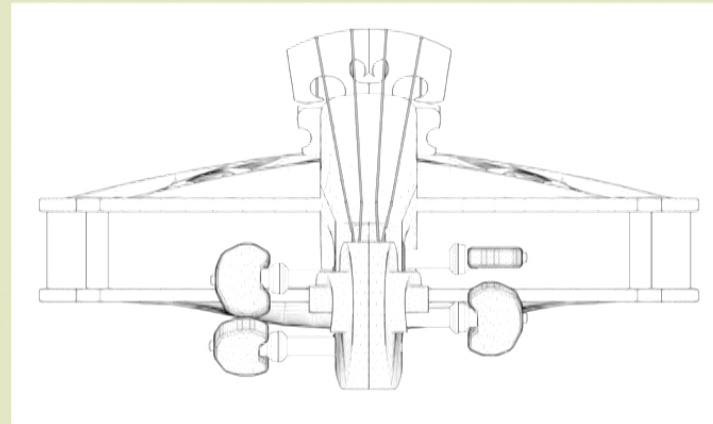

The vibrational modes of a violin body resonances are as fixed as those of a room, and can be considered a linear system

Do old violins project better than new ones?



Paris experiment: ~50 experienced listeners, 3 new violins, 3 by Stradivari



Solo excerpt (Tchaikovsky) ABAB



With orchestra (Sibelius) ABAB

Paris projection results (paper appearing soon in PNAS)

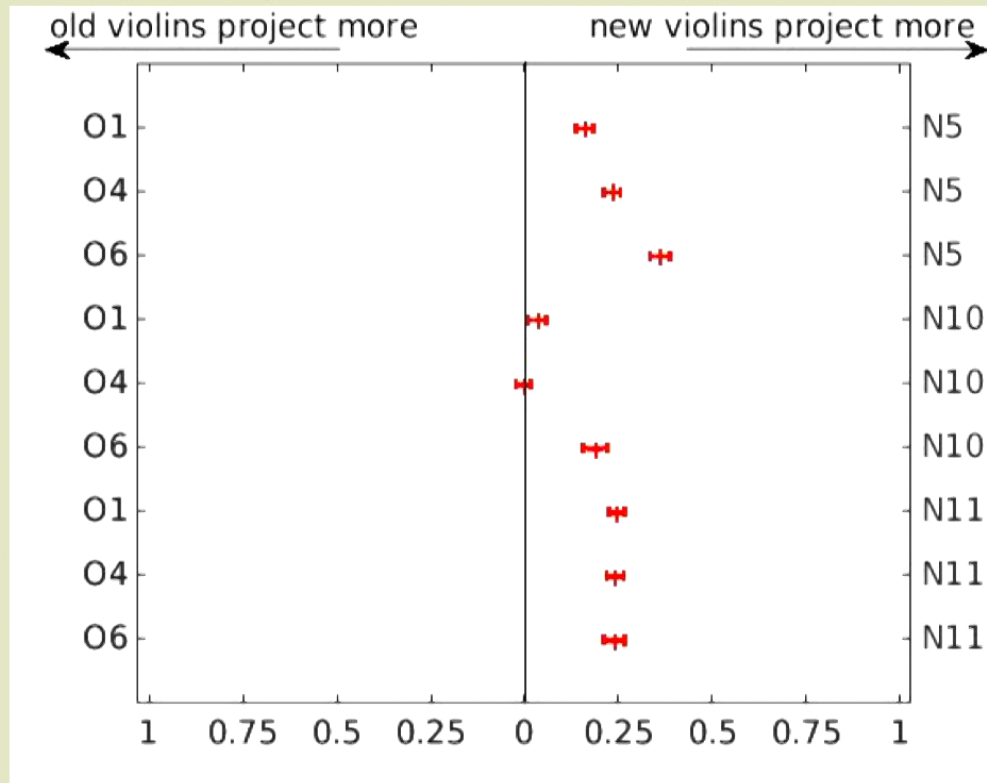

Relative projection of each Strad and each new violin (averaged over all players, with and without orchestra)

Projection & listener preference: the NY experiment



Grand Hall, Cooper Union NY

- Audience of about 50 experienced listeners
- 3 new violins, 3 by Stradivari
- Series of short ABAB comparisons

New York Results: projection & preference

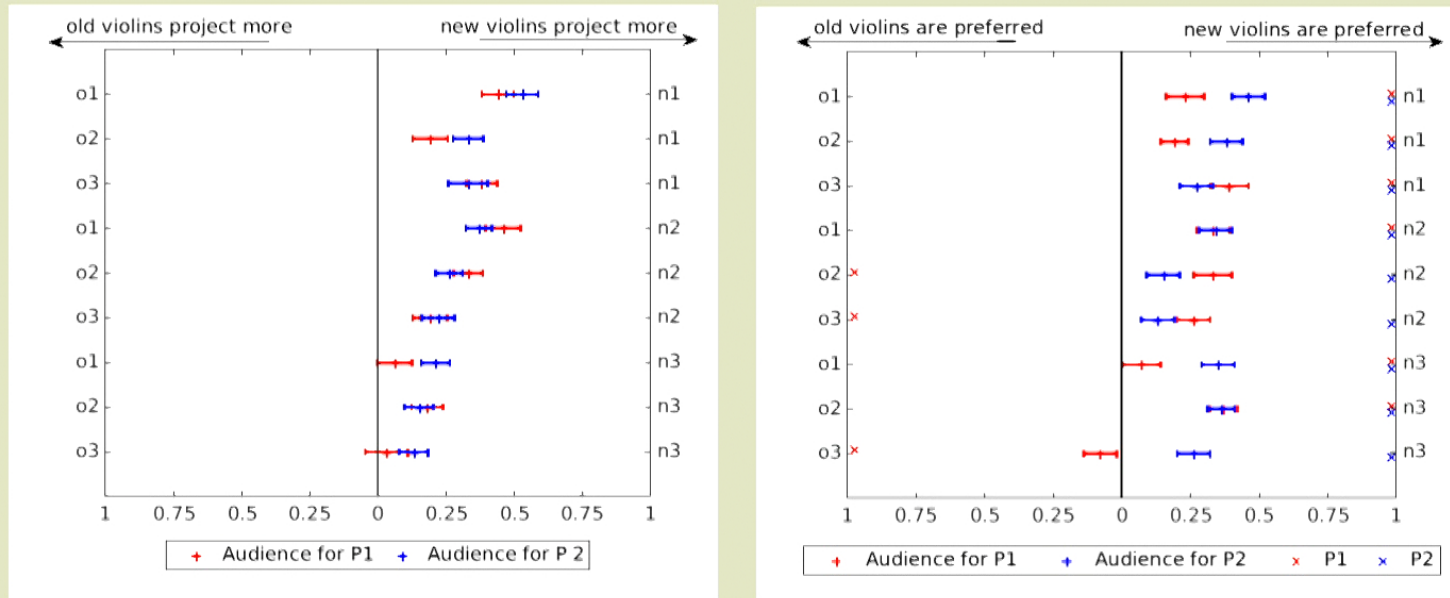

Preferred violins were on average better projecting

Objective parameters for violin quality

a long-standing goal of violin research



blind tests



acoustical measurements

Measurement most associated with tone quality: *spectrum*

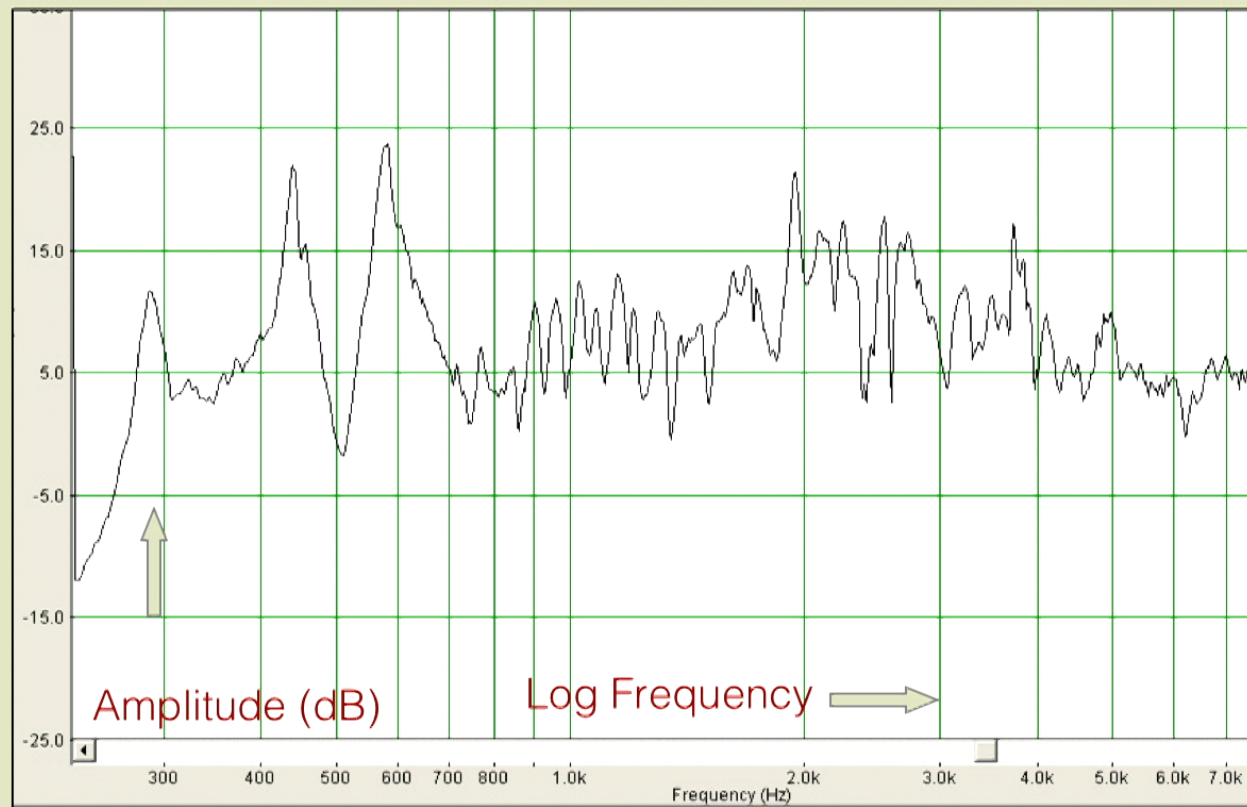

First ever audio spectrum analyser



Rudolph Koenig, 1832 – 1901

Another approach



Joseph Fourier 1768 – 1830



Measuring violin sound radiation



Radiativity: sound pressure at mic position, per-unit-force at bridge

Acquisition application by George Stoppani

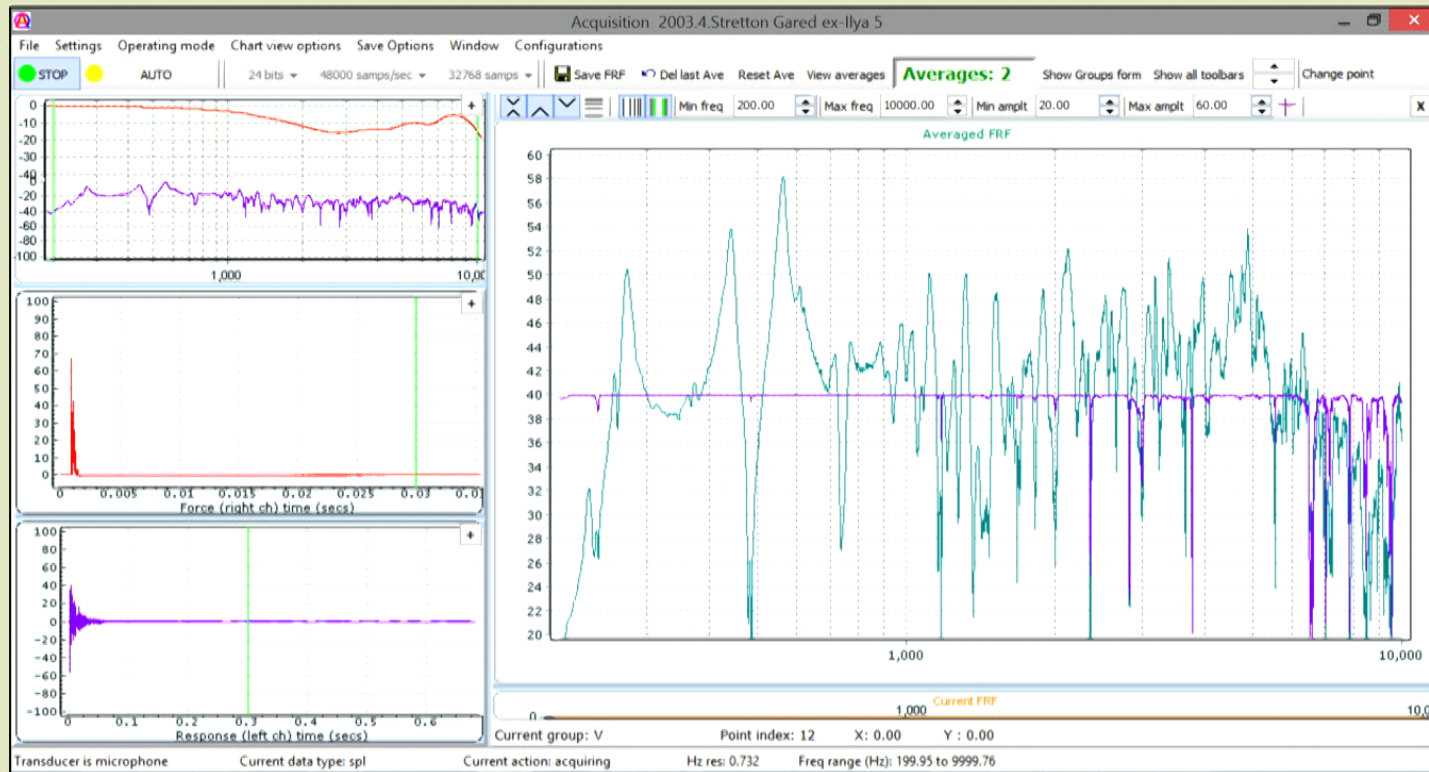

To reduce noise, take complex average of 5 taps at each mic position

isotropic monopole radiation

individual "signature" modes, volume change

increasingly directional radiation

multiple overlapping modes "directional tone color"

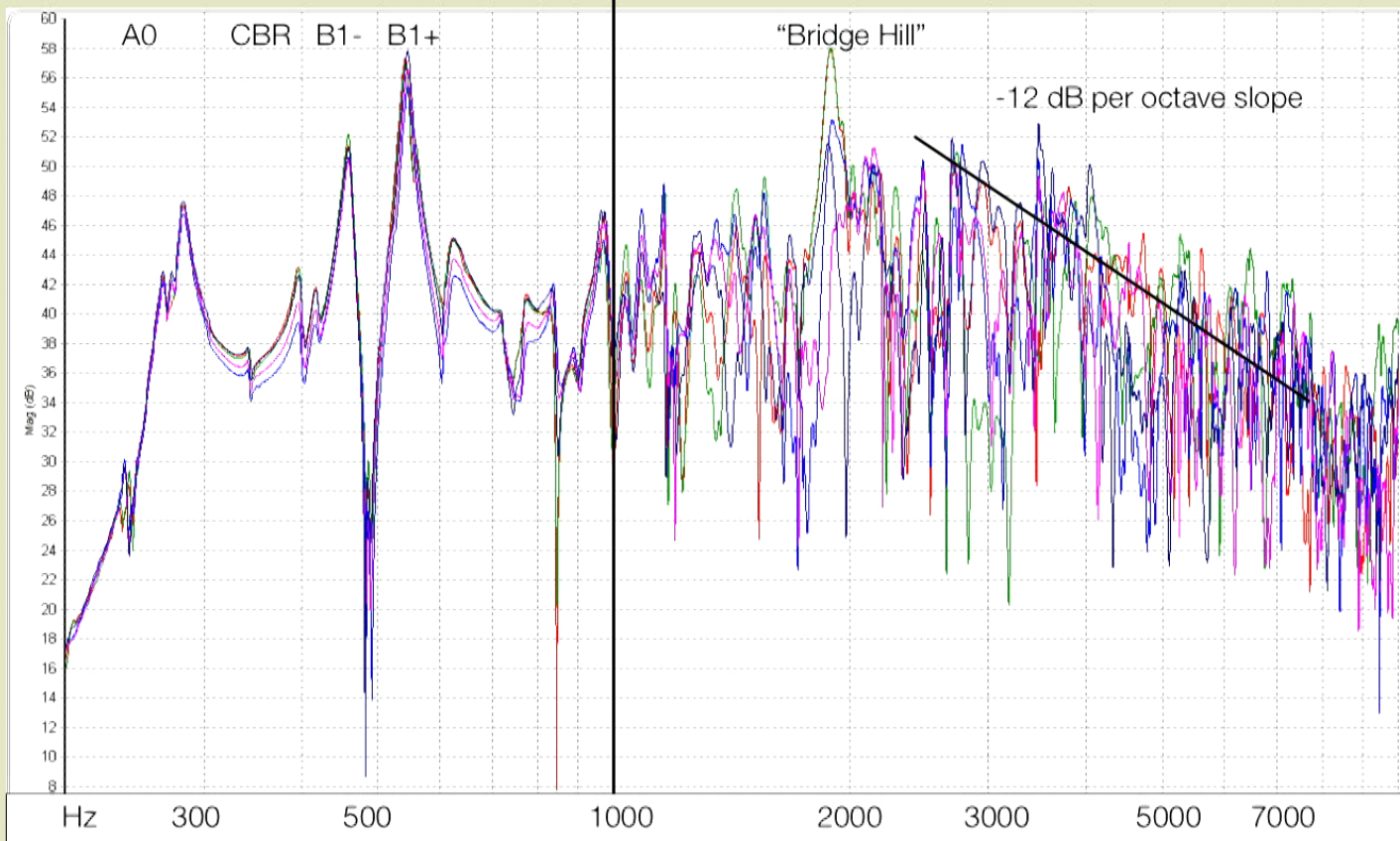

1734 Stradivari, 5 frontal microphone positions, 30° spacing



FRF can be transformed into an impulse response – and back

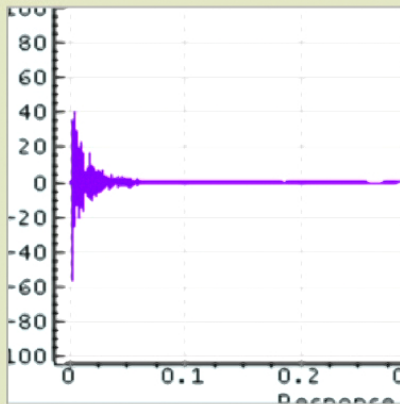
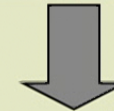
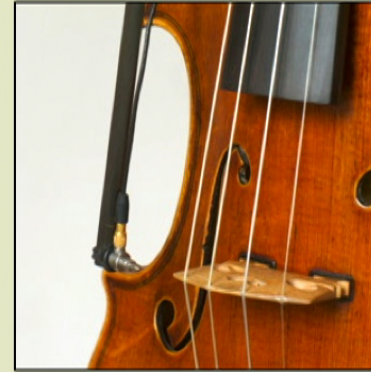

Impulse response

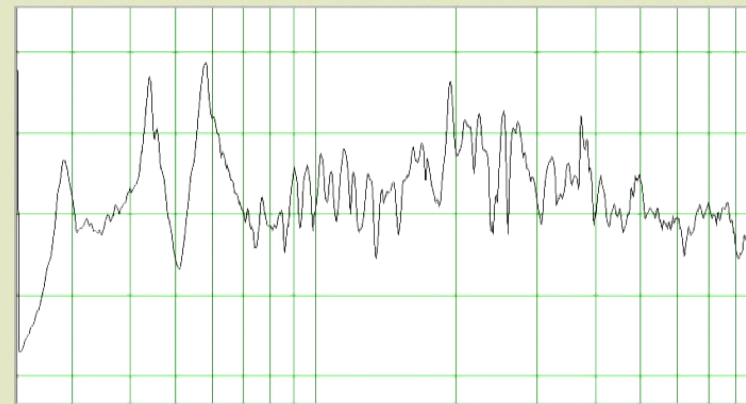

Complex FRF (phase not shown)



Physicist Gabriel Weinreich



Convolution



IR (mic 1, "Cathedral" Stradivari)



electric violin

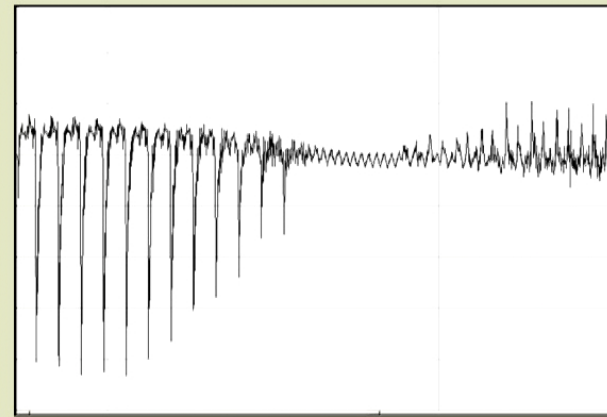
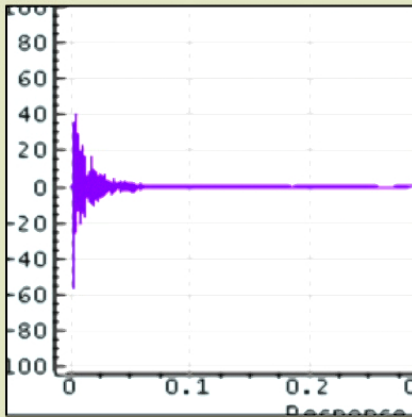

Guarneri del Gesu violin versus cigar Box

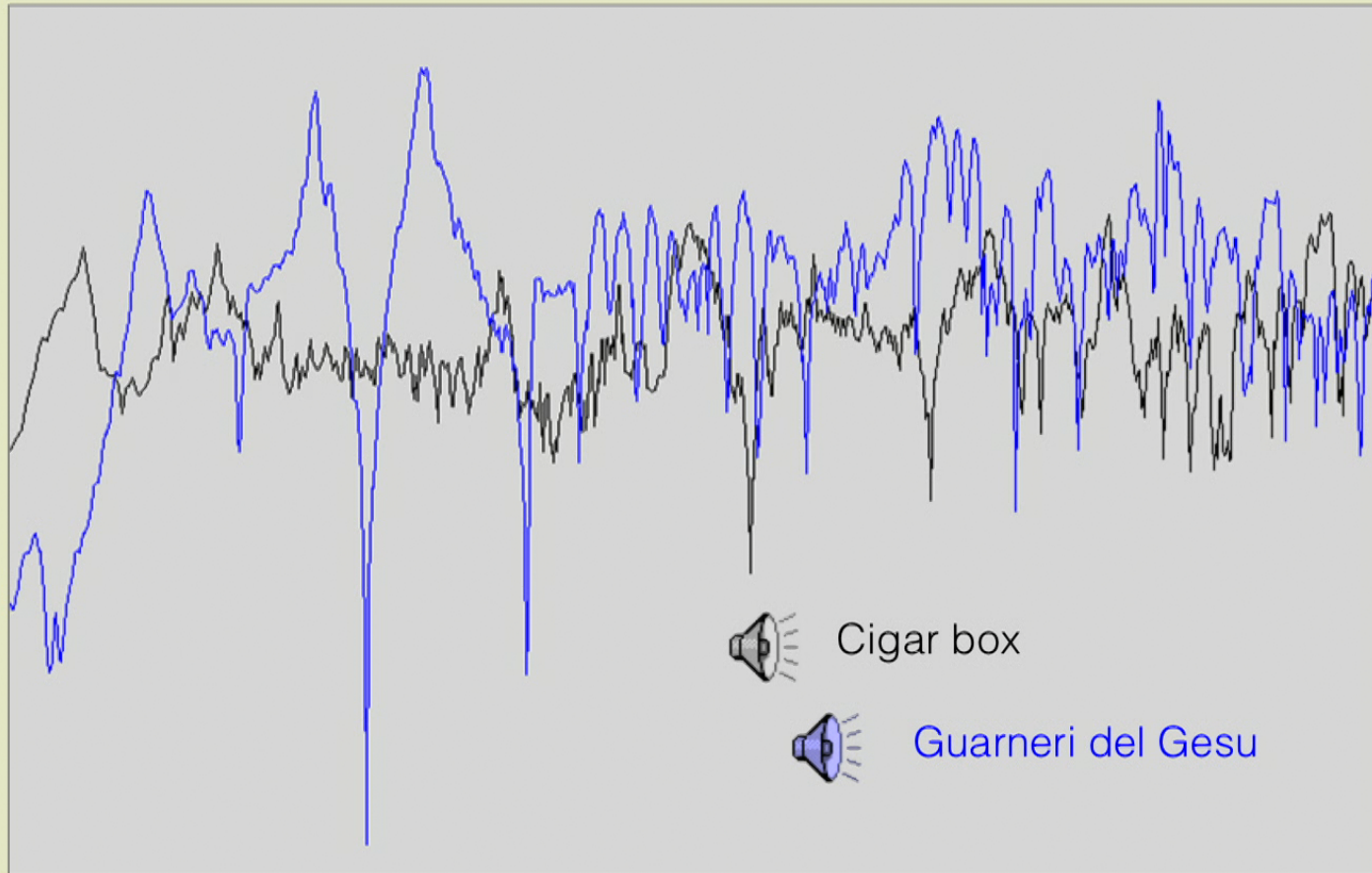

Objective quality parameters: historical

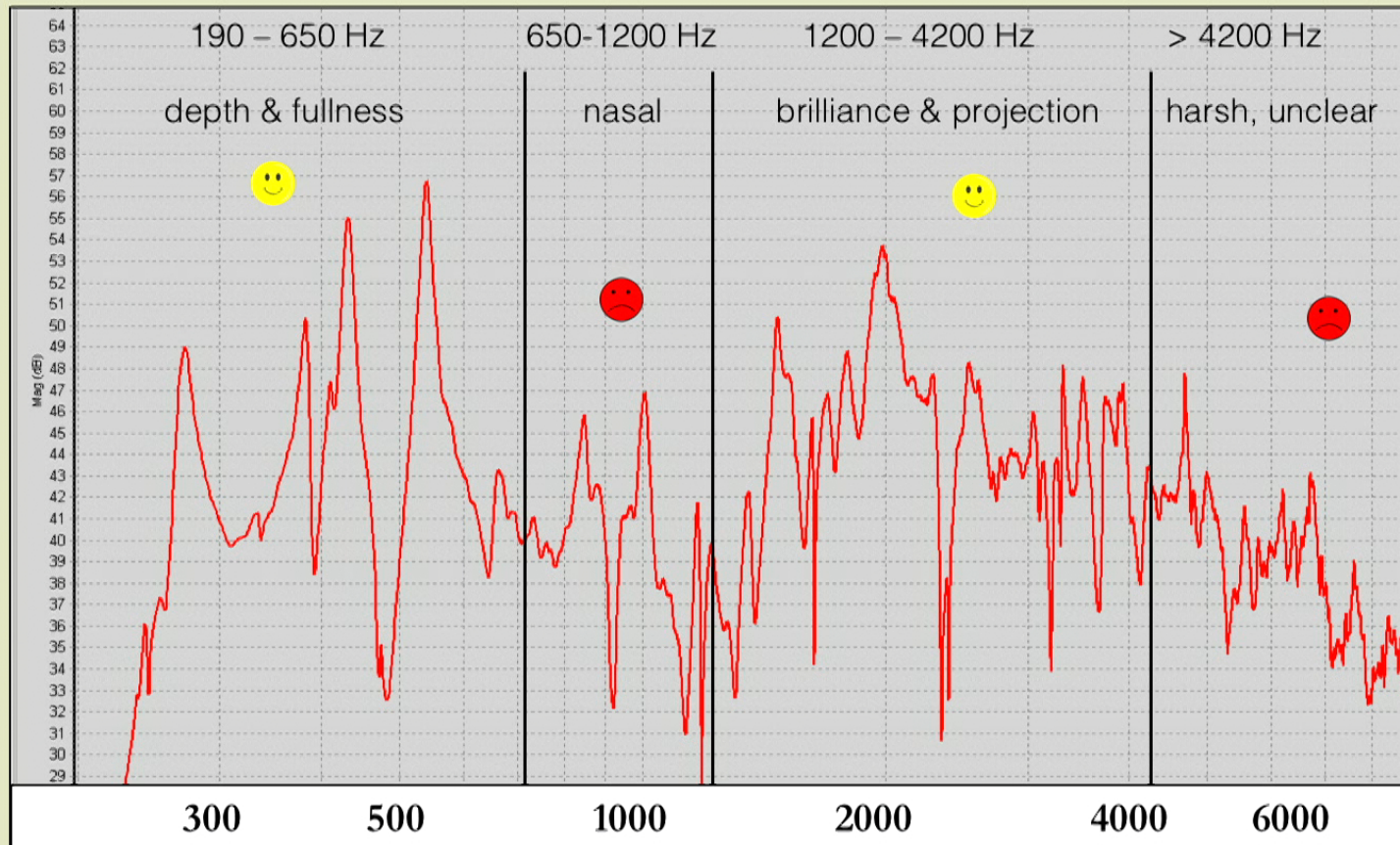

Meinel, Dünwald, Bazant

Evenness across spectrum

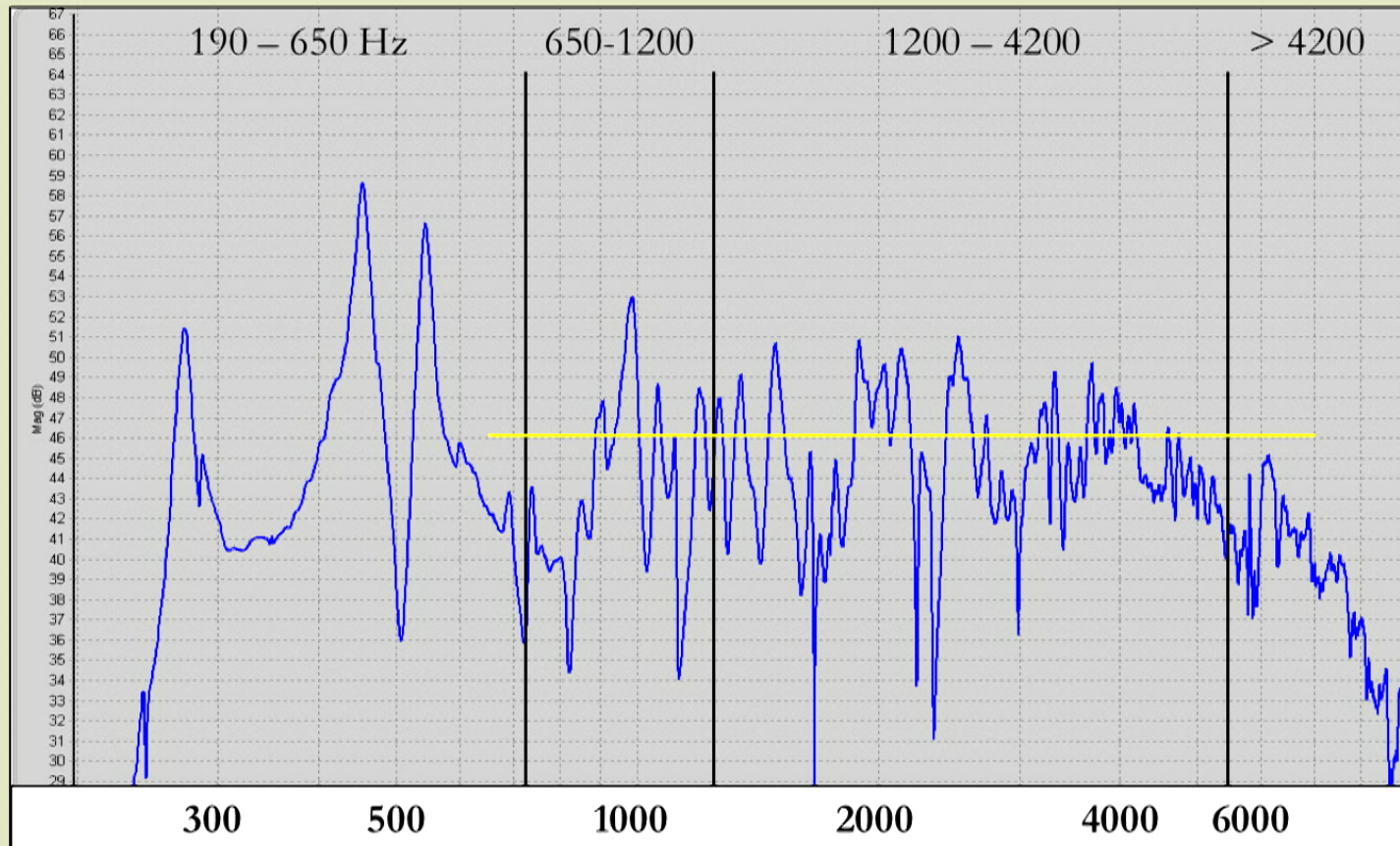

Langhof, Rodgers, Bissinger

All agree that A0 should be high in amplitude

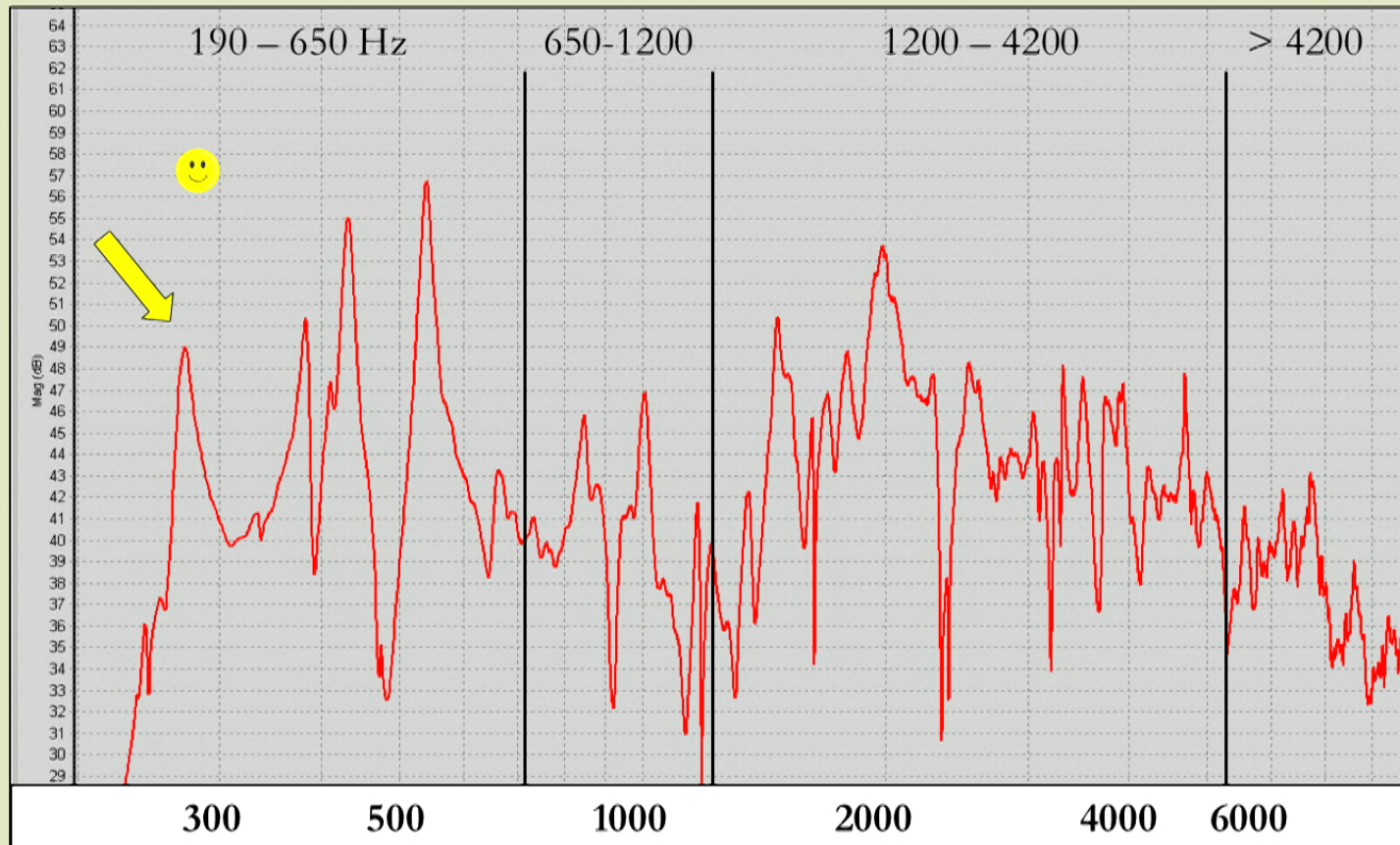

What about *how much* sound is radiated?

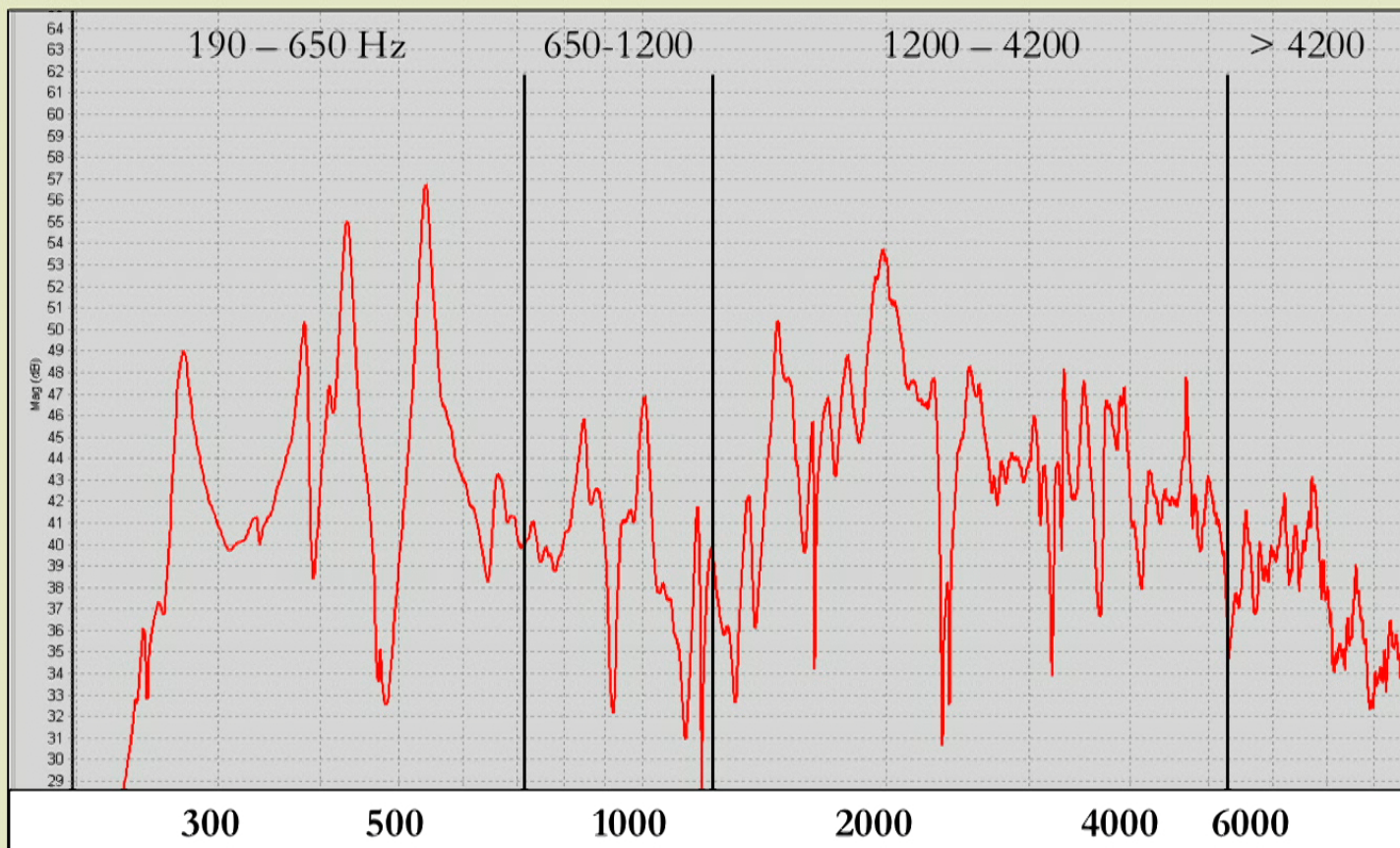

All 12 Paris test violins

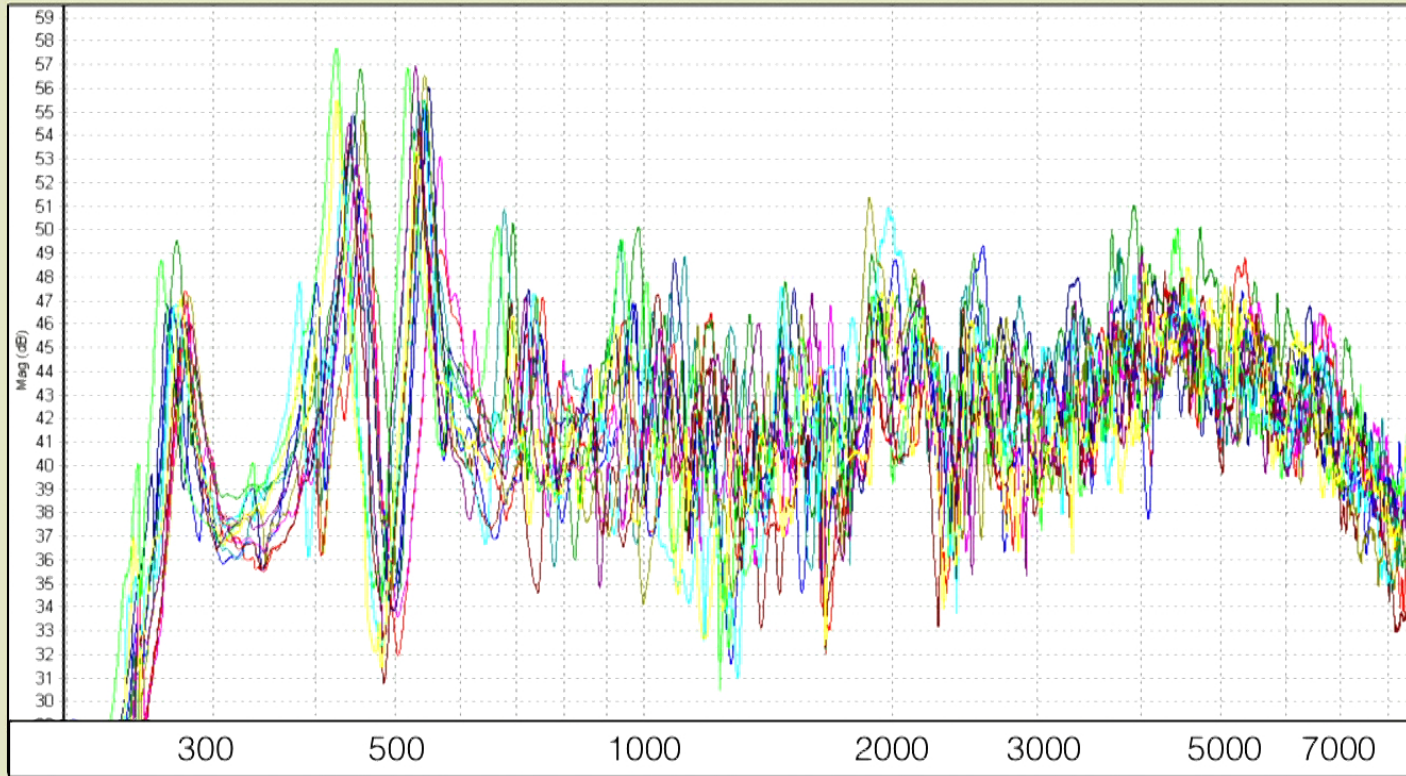

Average of all 12 test violins

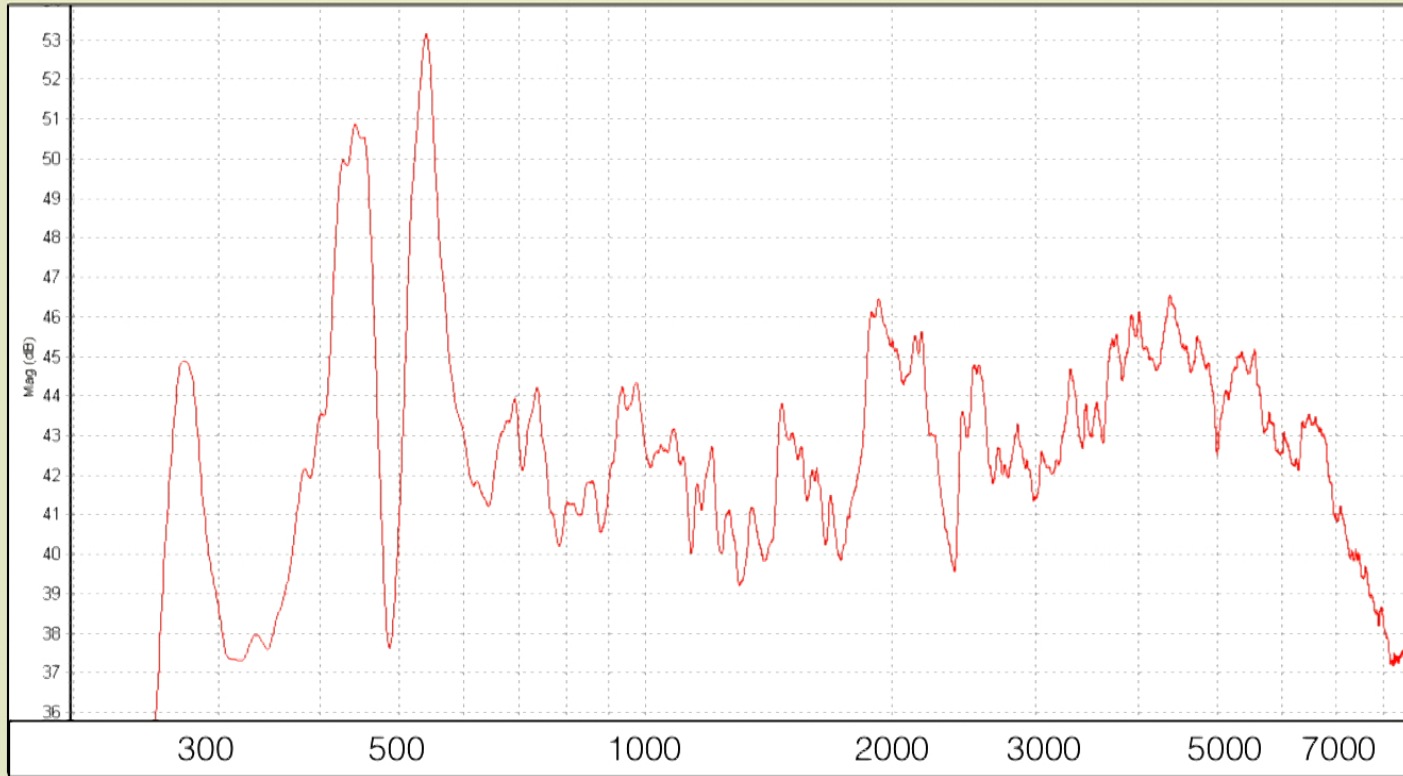

Average of all 12 test violins

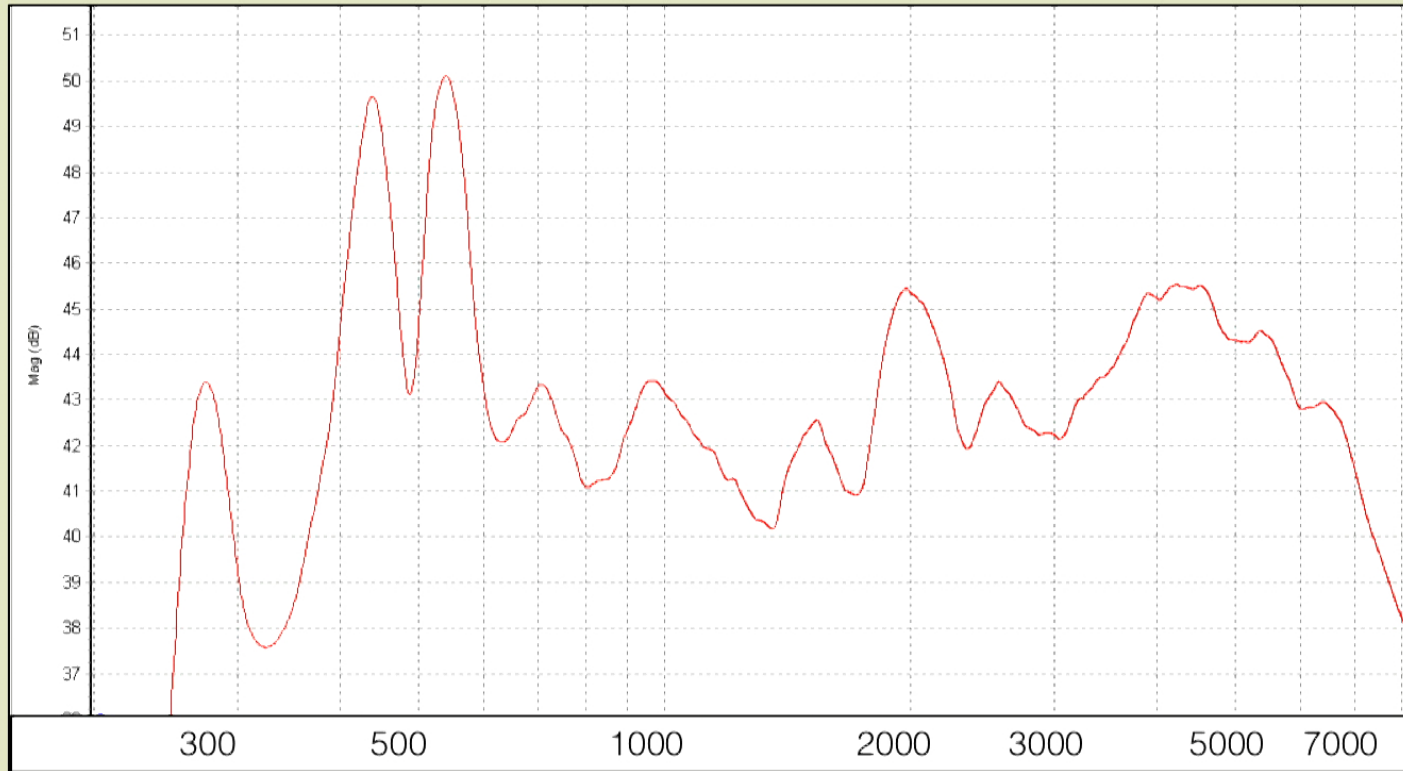

1/6th octave smoothing function

all new test violins all old test violins

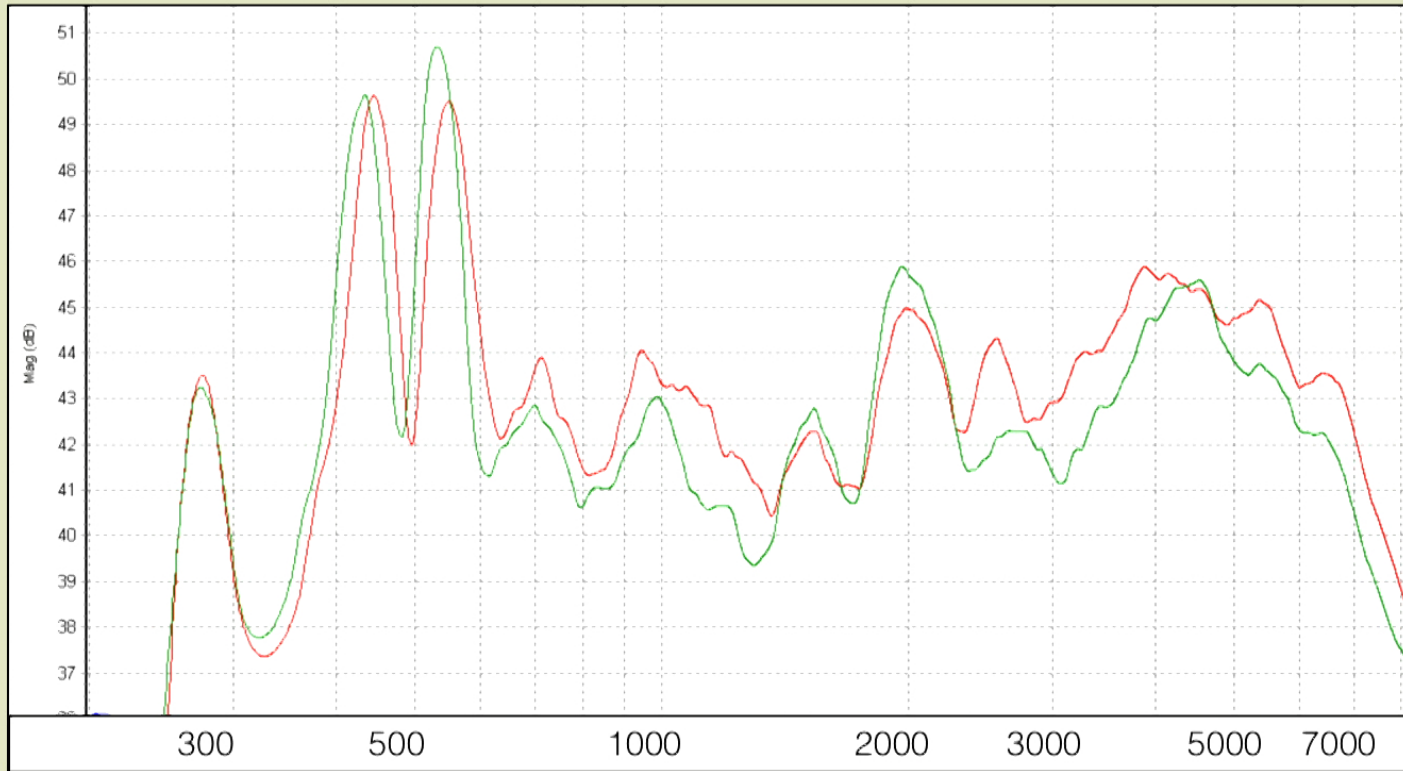

6 most-preferred 6 least-preferred

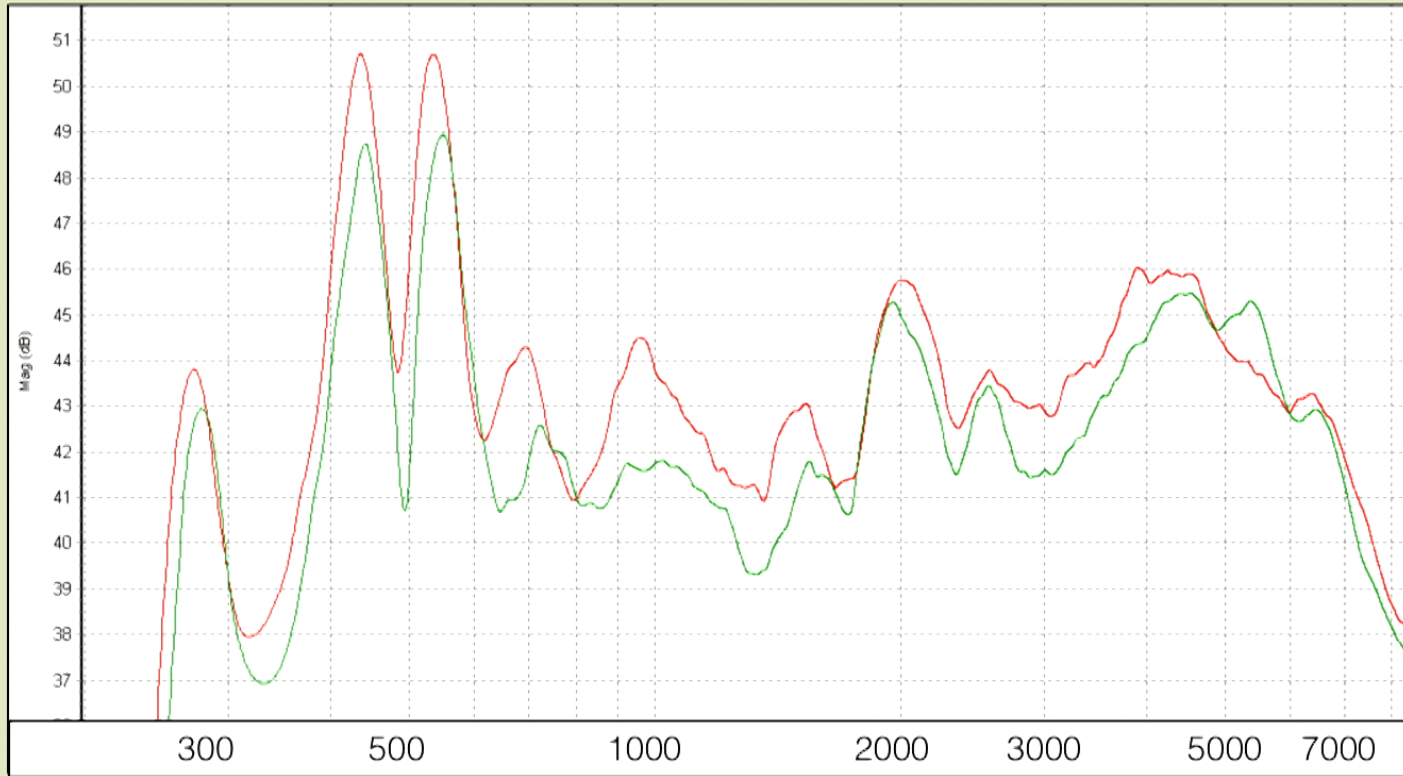

3 most-preferred 3 least-preferred

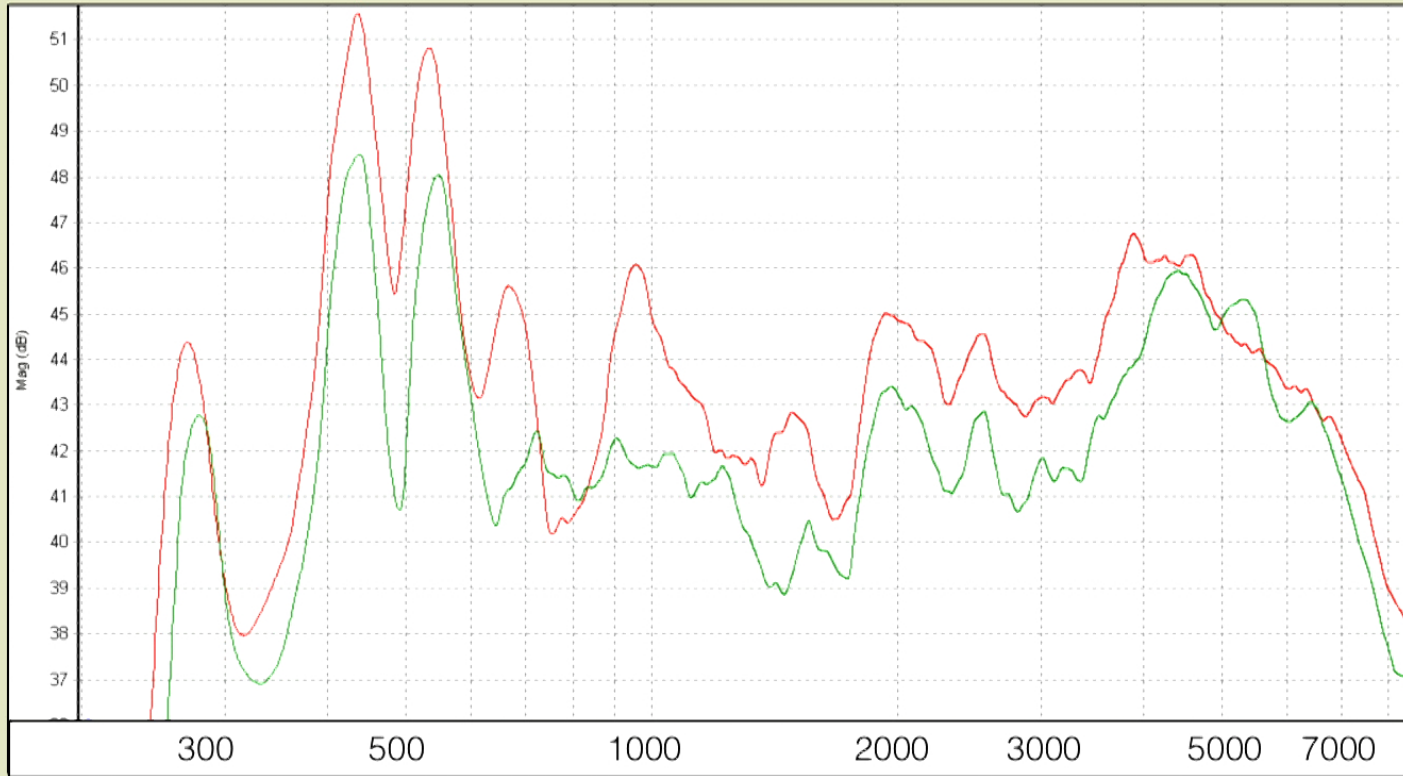

2 most-preferred 2 least-preferred

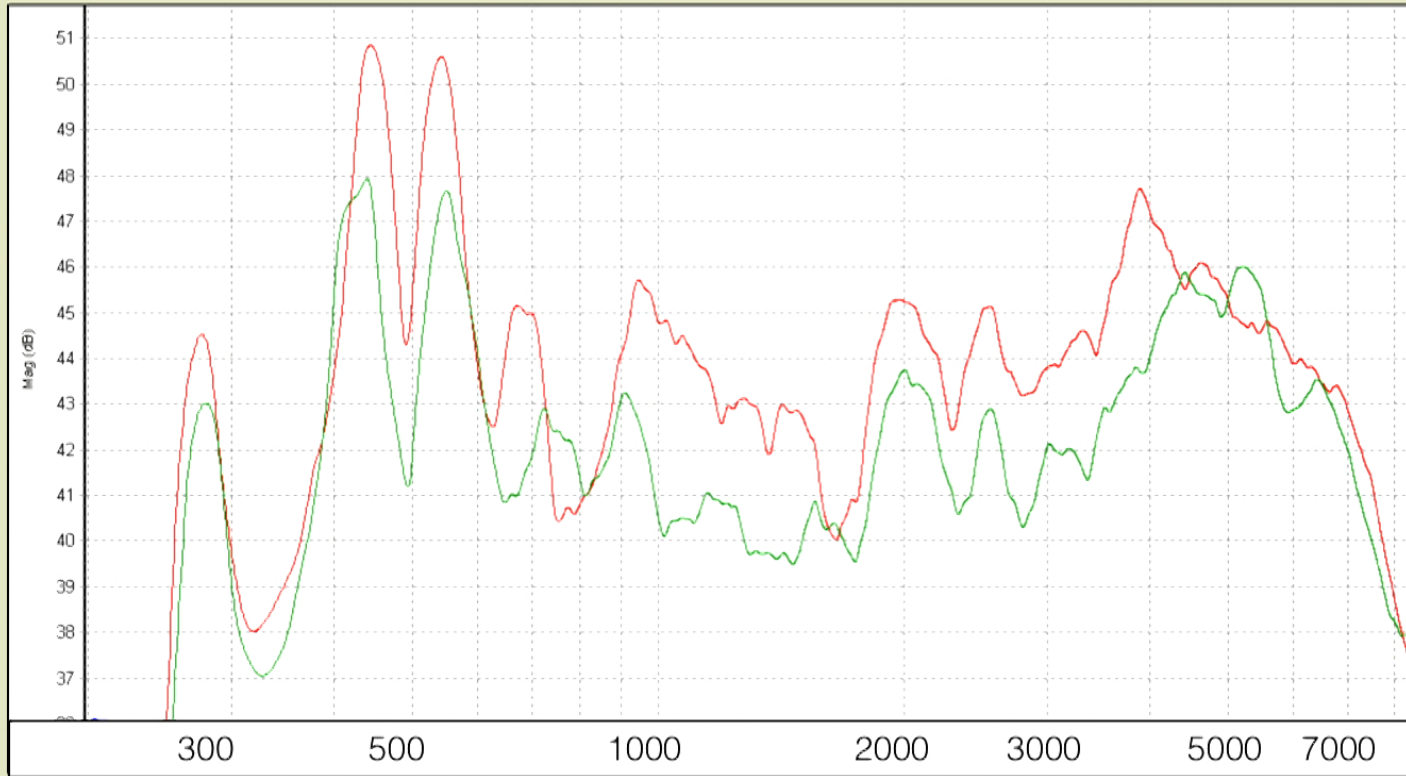

single most-preferred single least-preferred

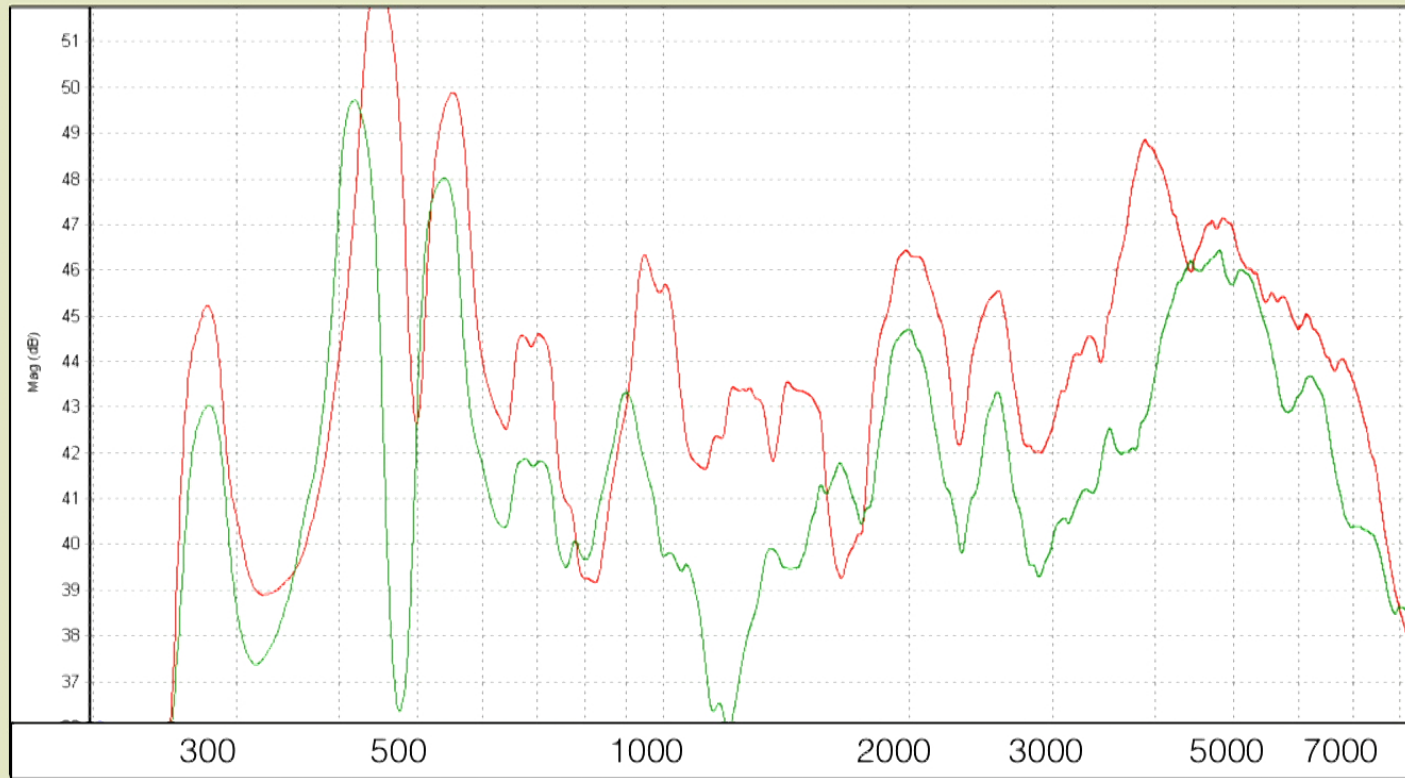

3 most-preferred new 3 least-preferred new

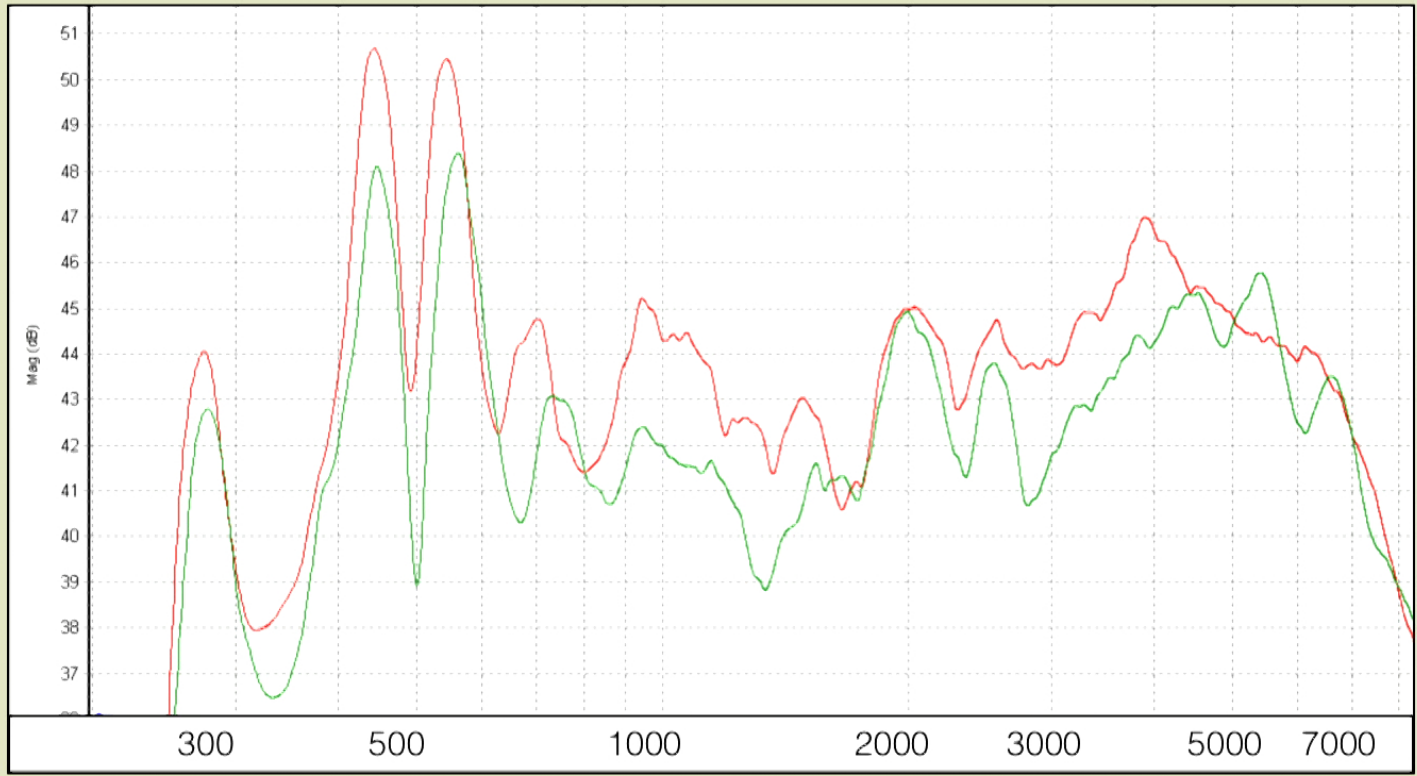

Equal loudness curve (ISO 226: 2003)

Maximum sensitivity ~ 3.8 kHz

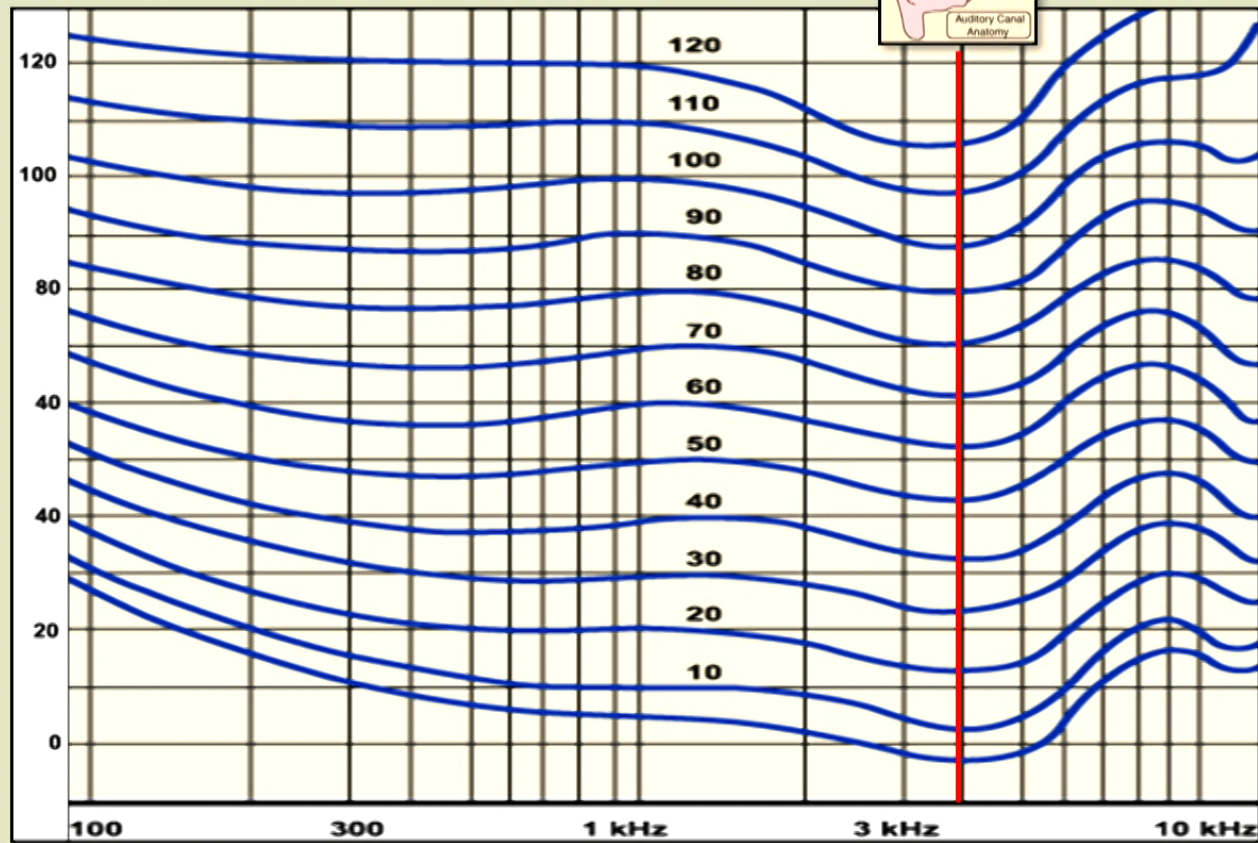
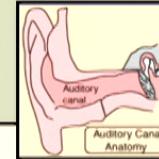

All 12 test violins

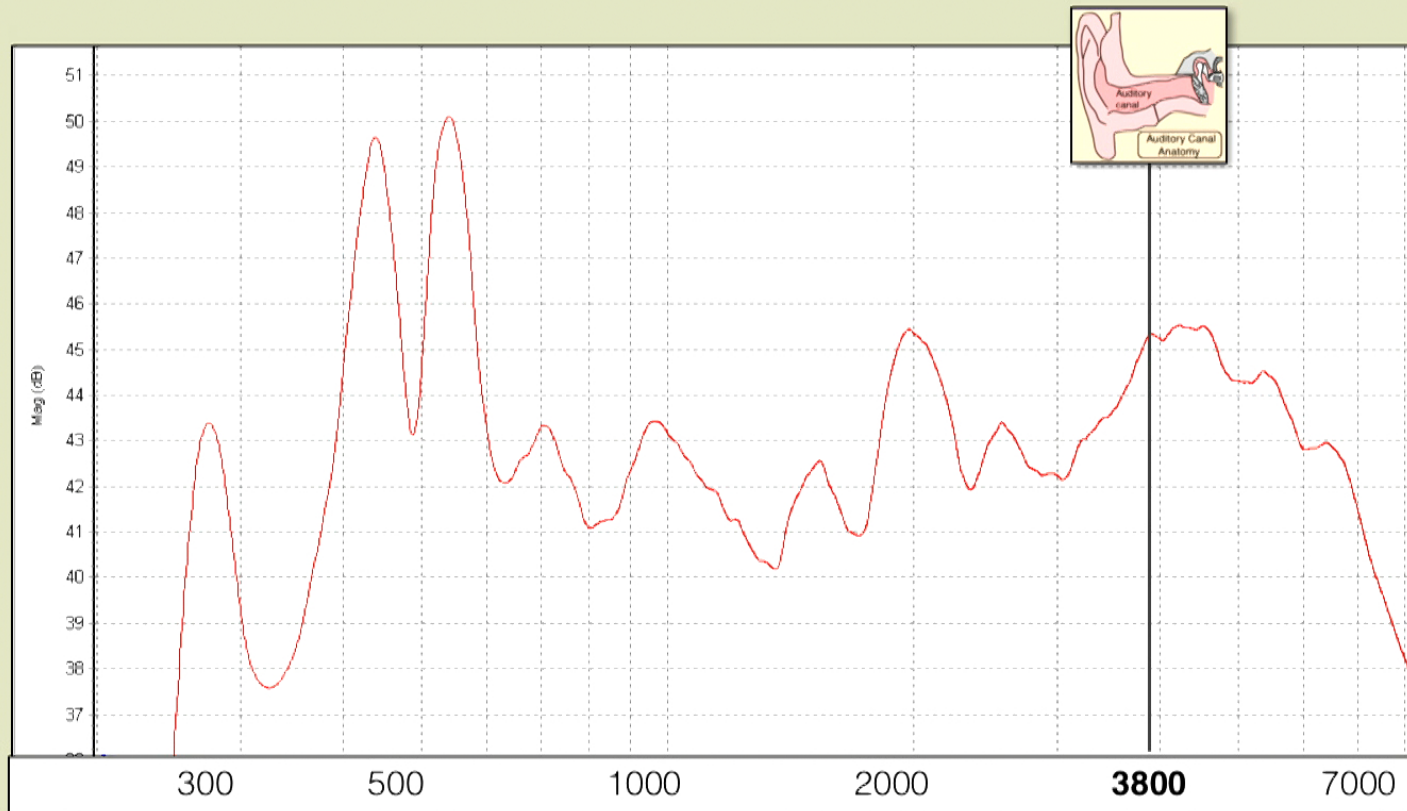

1/6th octave smoothing function

6 most-preferred 6 least-preferred

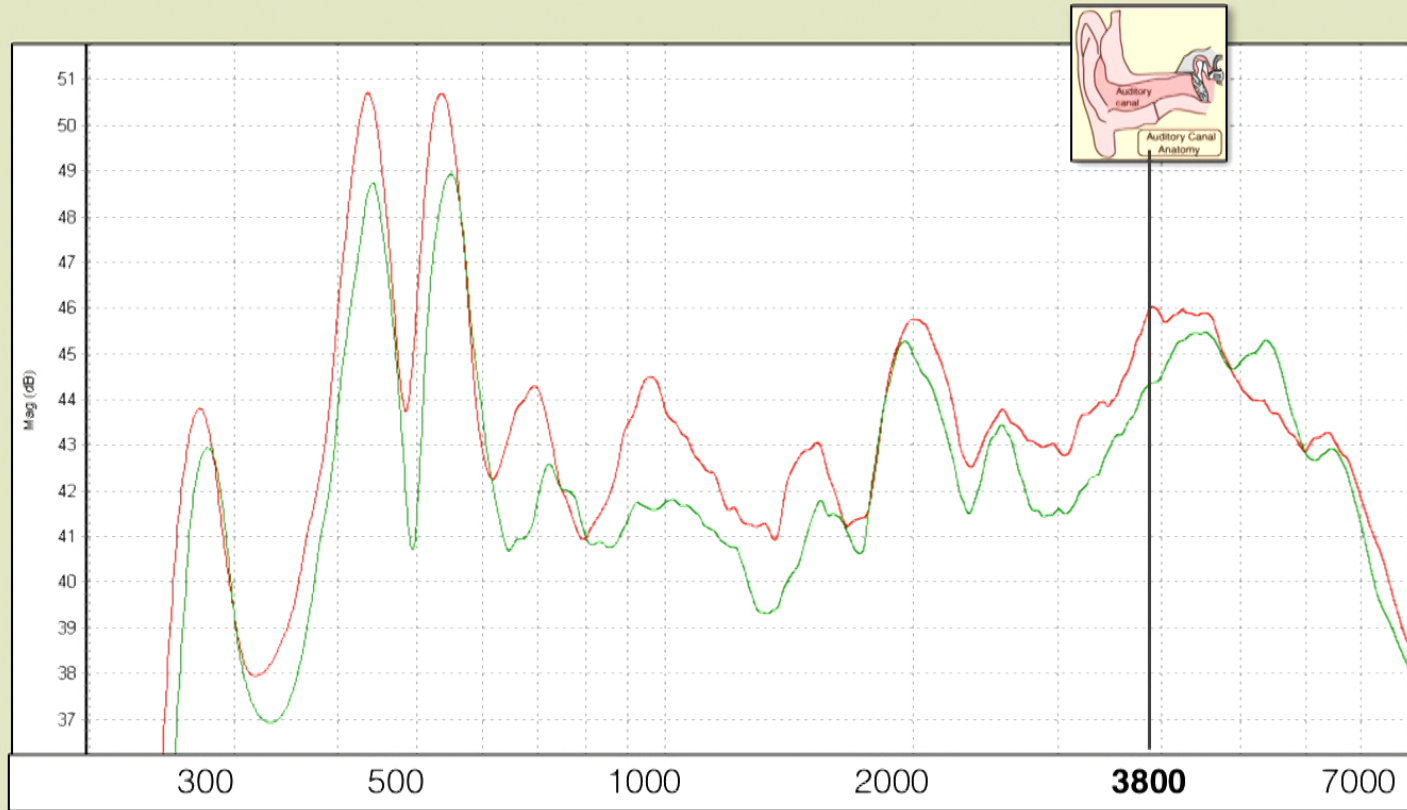

3 most-preferred 3 least-preferred

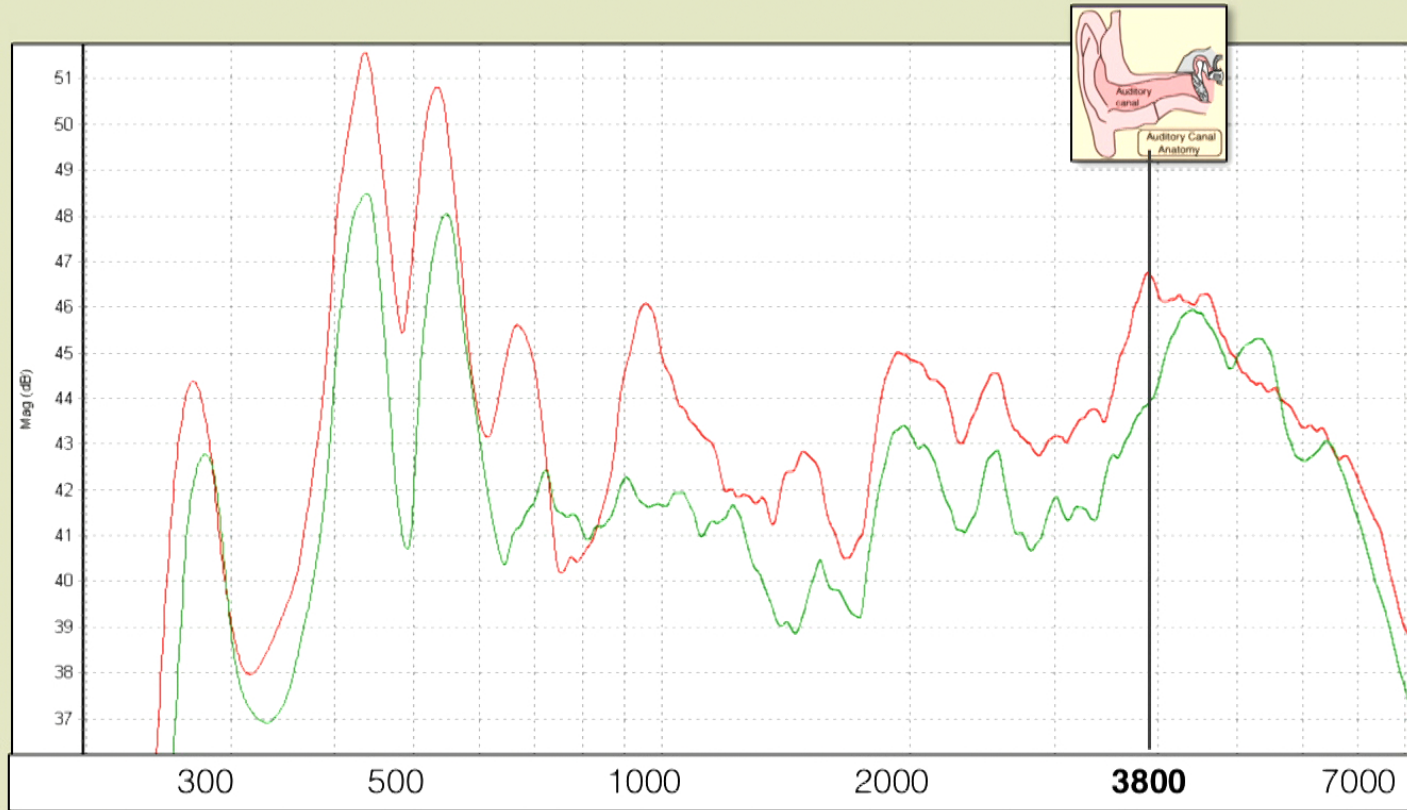

2 most-preferred 2 least-preferred

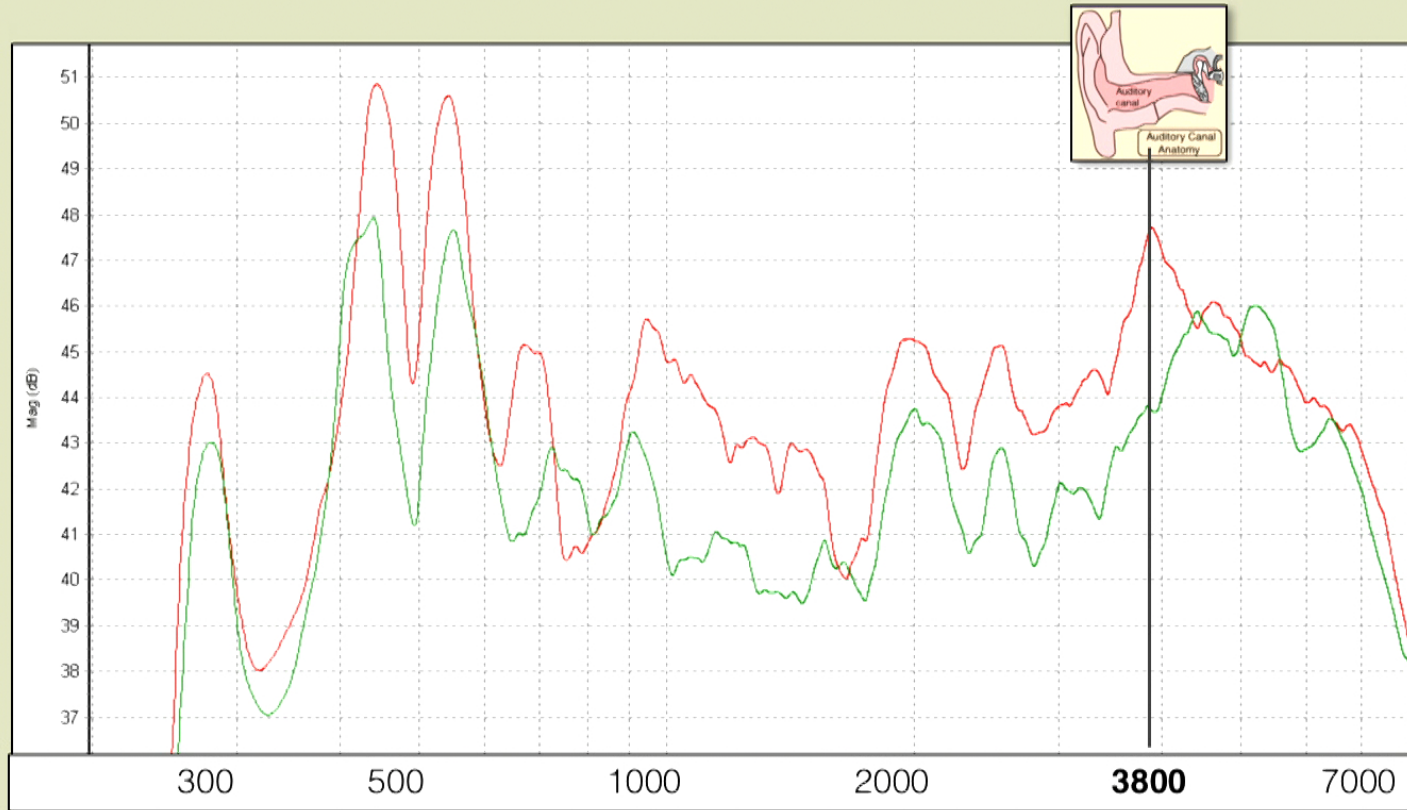

single most-preferred single least-preferred

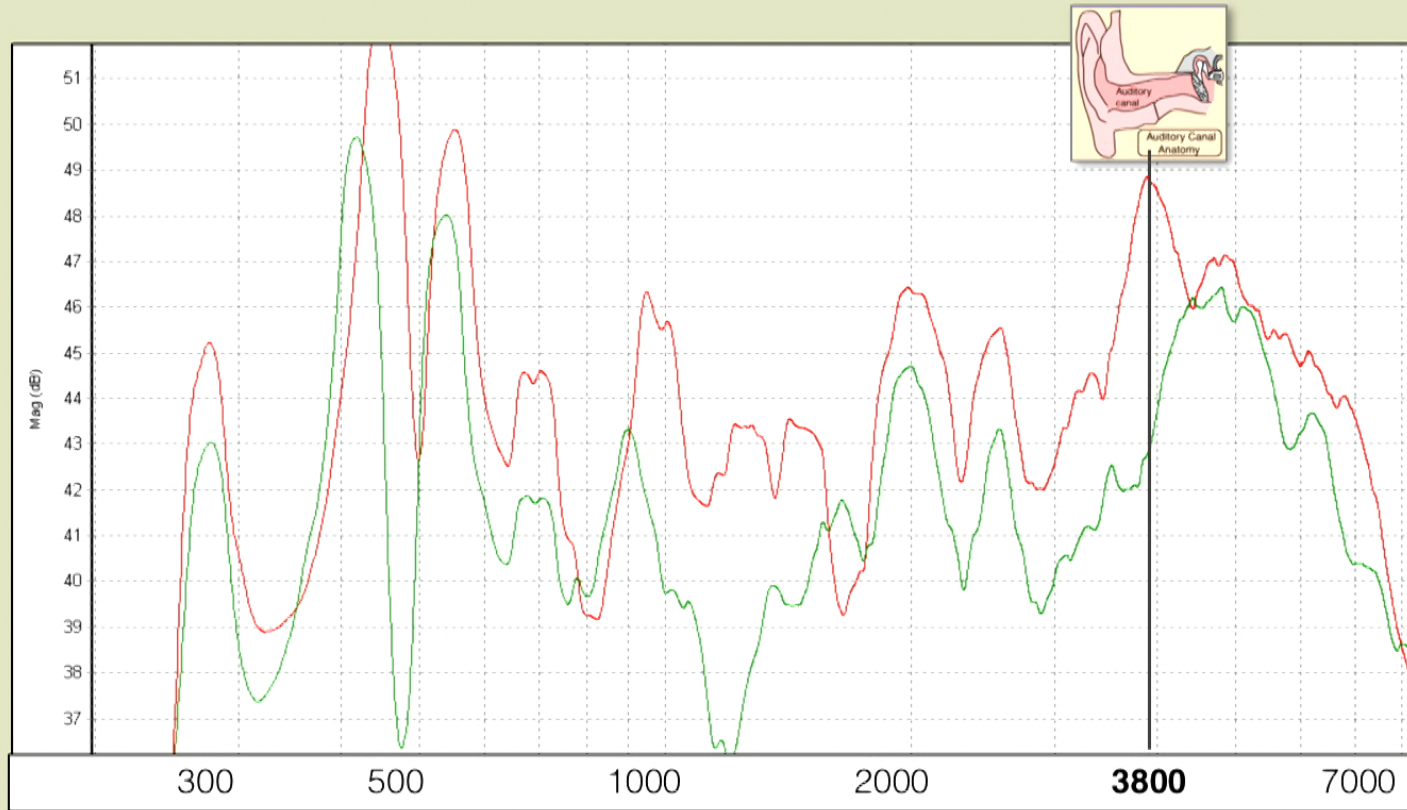

Is there a unique definition of violin quality?

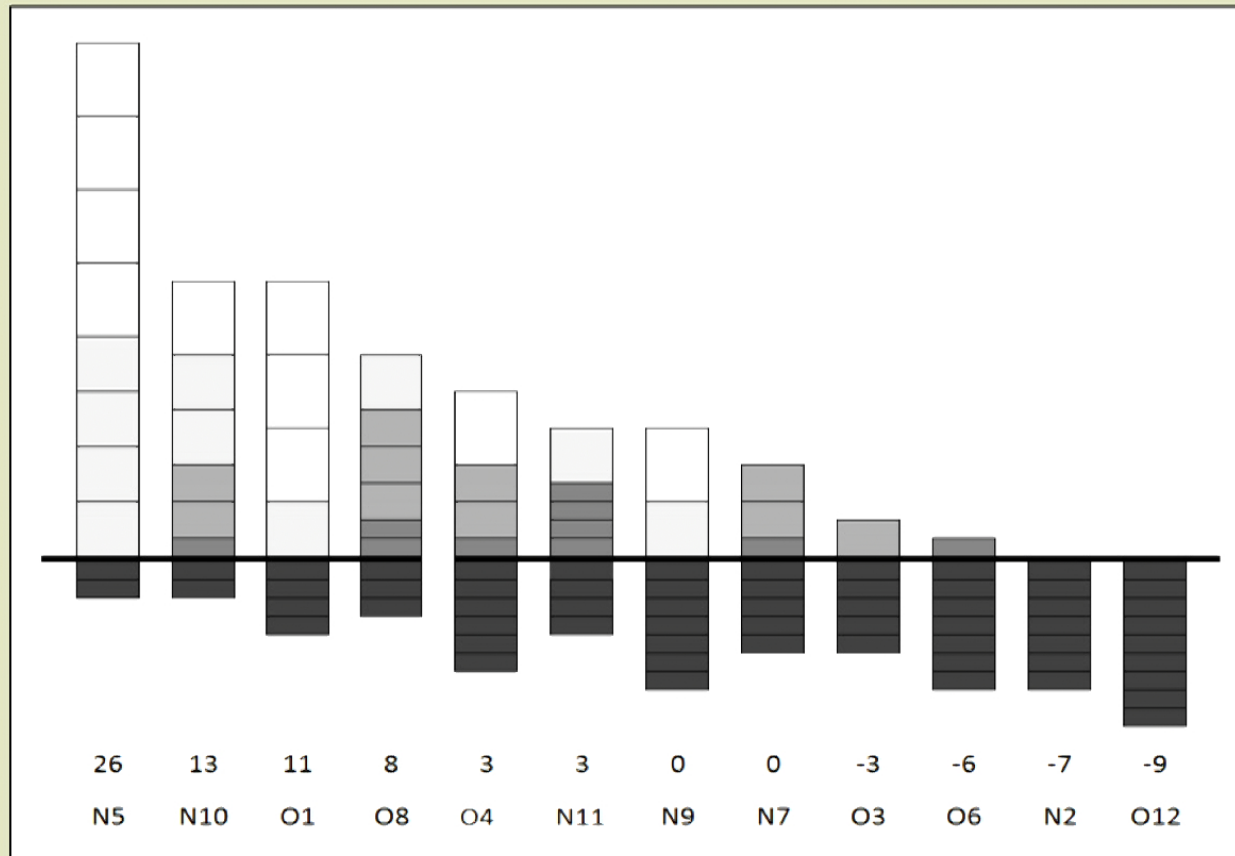

Number of soloists who chose each violin:

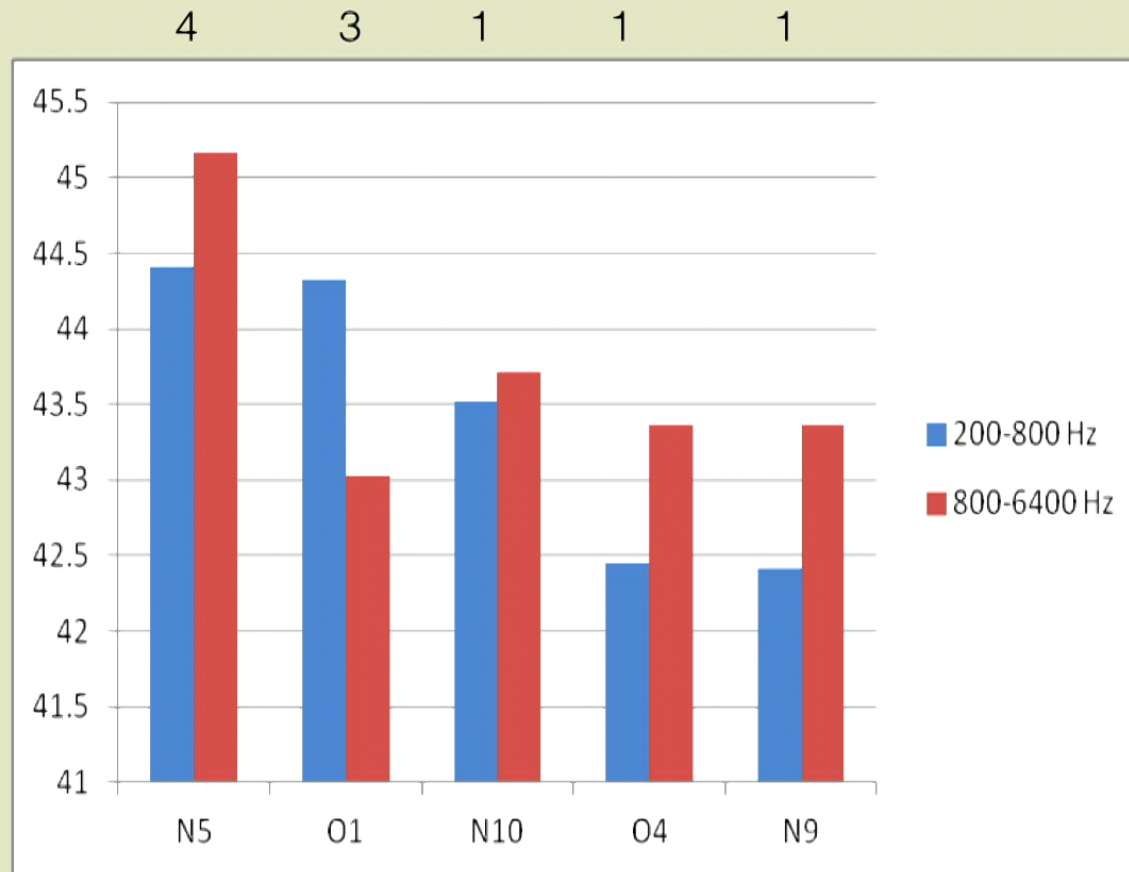



”If we knew what it is a good violin does, and then designed an instrument that did only that, I’d be surprised if it looked like a traditional violin.”

Gabriel Weinreich

Mercedes Formula 1 steering wheels

1954

2014





Bugati Type 35
1920s

Ferrari F2004
2004



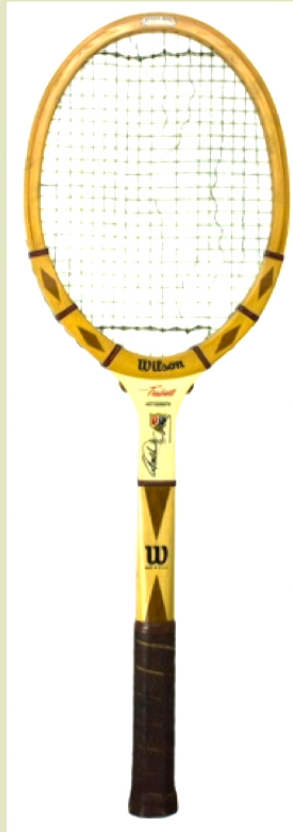

Arthur Ashe, 1968
Wilson "Tony Trabert Autograph"



Serena Williams, 2014
Wilson "Blade"



“Betts” Stradivari
1704

copy of “Betts” Stradivari
2011

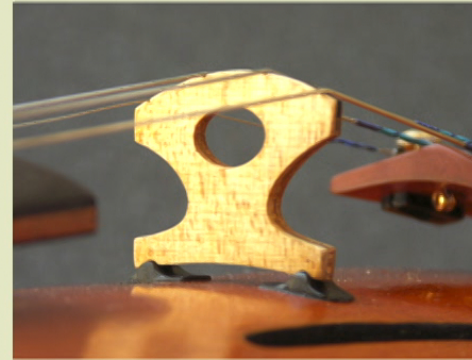
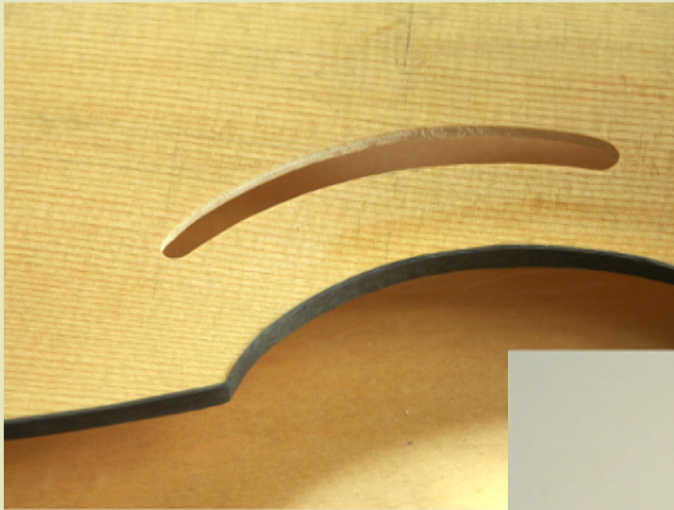

Can the violin
begin evolving
again?

