

Title: The CA interpretation of quantum mechanics

Date: May 14, 2015 02:00 PM

URL: <http://pirsa.org/15050094>

Abstract: The CA interpretation presents a view on the origin of quantum mechanical behavior of physical degrees of freedom, suggesting that, at the Planck scale, bits and bytes are processed, rather than qubits or qubites, so that we are dealing with an ordinary classical cellular automaton. We demonstrate how this approach naturally leads to Born's expression for probabilities, shows how wave functions collapse at a measurement, and provides a natural resolution to Schroedinger's cat paradox without the need to involve vague decoherence arguments. We then continue to discuss the implications of Bell's inequalities, and other issues.

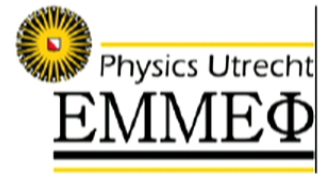

May 14, 2015

# The Cellular Automaton Interpretation of Quantum Mechanics

*First Principles*

Gerard 't Hooft

Issues we wanted to address:

- ) Quantum gravity
- ) Black hole information
- ) Questions concerning the Standard Model ...

Instead, we find answers to:

- ) The measurement problem
- ) Collapse of wave function
- ) Schrödinger's cat
- ) Born probability
- ) and a surprising answer (perhaps) to:

At the most basic level of physics (Planck scale):

No mysticism  
No probabilities  
No Hilbert space

Only logical laws about the way *classical* information is processed:

No qubits  
No complex numbers  
No real numbers

Just information – we do have bits and bytes ...  
and *causality* – so we do have space and time

## Nature as a collection of cogwheels

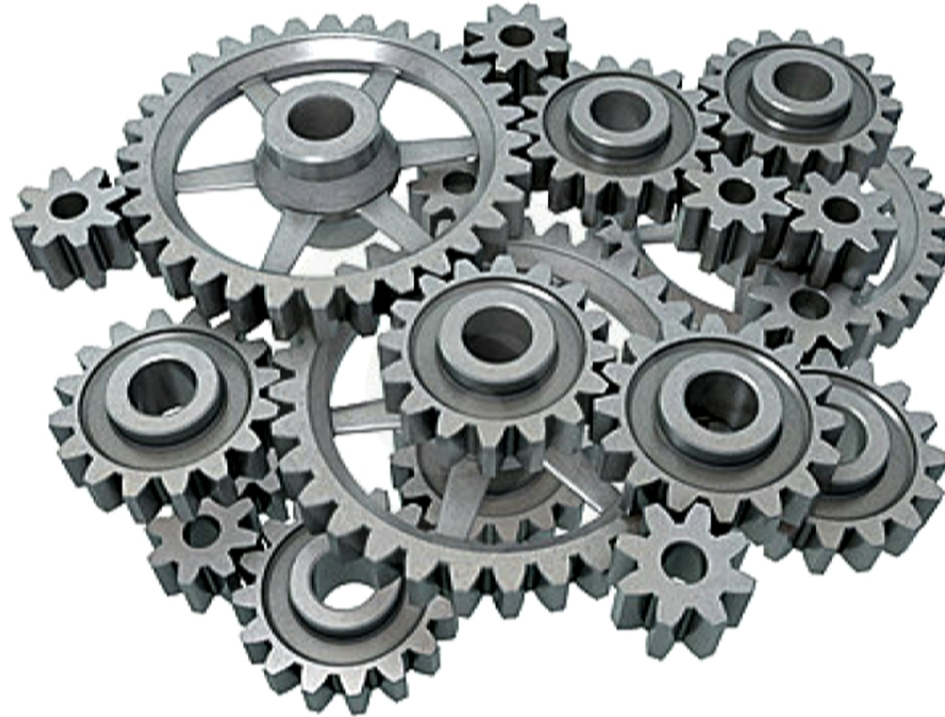

A fundamental ingredient of a generic theory: a finite, periodic system: the *Cogwheel Model*:

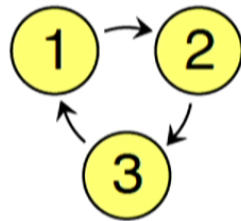

A fundamental ingredient of a generic theory: a finite, periodic system: the *Cogwheel Model*:



$$U(\delta t) = \begin{pmatrix} 0 & 0 & 1 \\ 1 & 0 & 0 \\ 0 & 1 & 0 \end{pmatrix} = e^{-iH\delta t} \quad U^3(\delta t) = \mathbb{I}$$

$$H = \frac{2\pi}{3\delta t} \begin{pmatrix} 1 & \kappa & \kappa^* \\ \kappa^* & 1 & \kappa \\ \kappa & \kappa^* & 1 \end{pmatrix}; \quad \kappa = -\frac{1}{2} + \frac{i\sqrt{3}}{6}; \quad \kappa^* = -\frac{1}{2} - \frac{i\sqrt{3}}{6}$$

A generic, finite, deterministic, time reversible model:

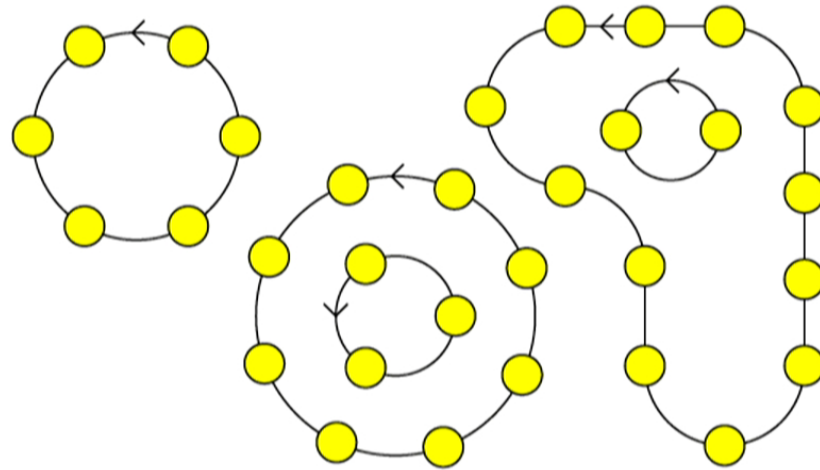



A generic, finite, deterministic, time reversible model:

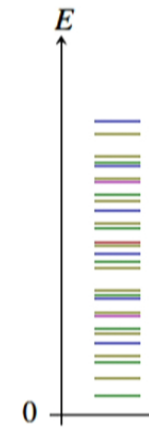
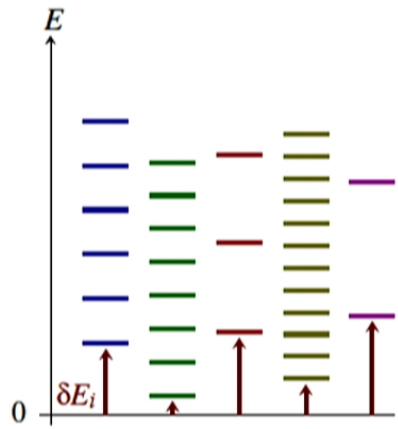
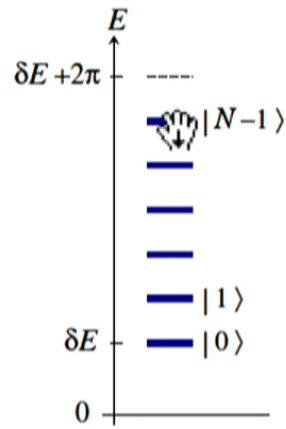
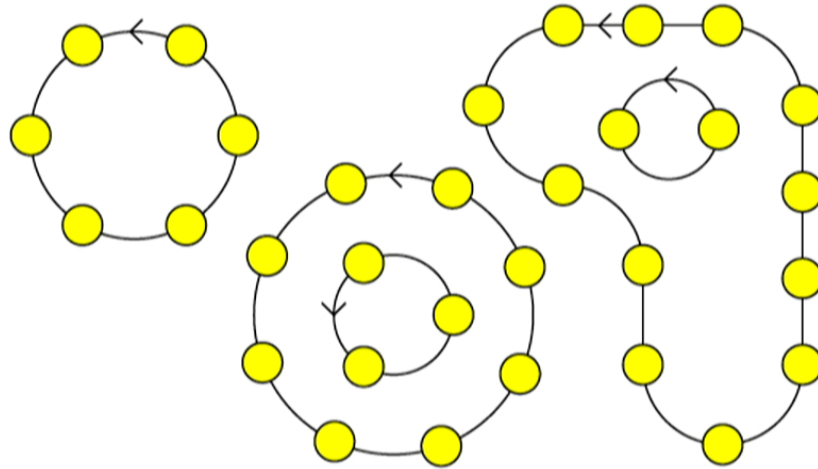

## The cellular automaton

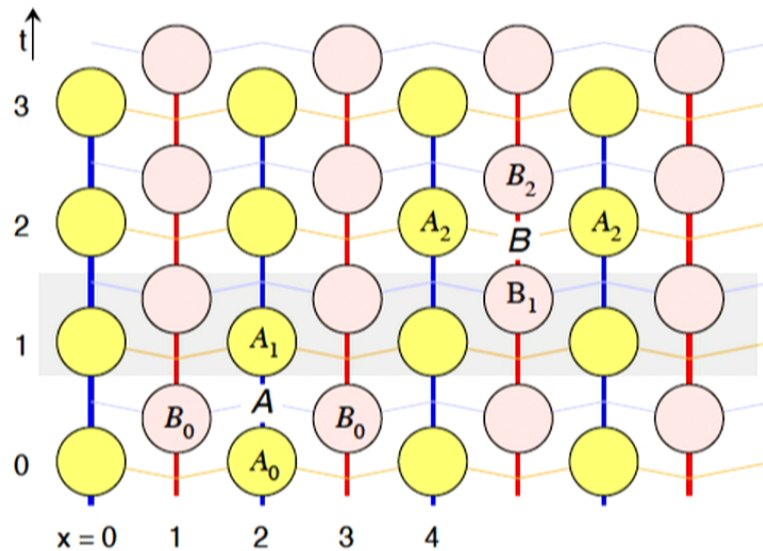

$$U = e^{-iH} = e^{-iA} e^{-iB} ; \quad A = \sum_x A(x) , \quad B = \sum_x B(x)$$

where  $[A(x), A(x')] = 0$  ,  $[B(x), B(x')] = 0$  ;  $[A(x), B(x')] \neq 0$   
 only if  $x$  and  $x'$  are neighbors. Baker Campbell Hausdorff :

$$H = A + B - \frac{1}{2}i[A, B] - \frac{1}{12}([A, [A, B]] + [[A, B], B]) + \dots$$

If we could cut off the CBH series at order  $N$ , then the Hamiltonian would obey

$$H = \sum_{\vec{x}} \mathcal{H}(\vec{x}) \quad \text{with} \quad [\mathcal{H}(\vec{x}), \mathcal{H}(\vec{x}')] = 0 \quad \text{if} \quad |\vec{x} - \vec{x}'| > N .$$

And:  $\mathcal{H}(\vec{x})$  would be bounded, so that this Hamiltonian has a *ground state (vacuum)*

In the continuum limit, this would be a *local quantum theory!*

If we could cut off the CBH series at order  $N$ , then the Hamiltonian would obey

$$H = \sum_{\vec{x}} \mathcal{H}(\vec{x}) \quad \text{with} \quad [\mathcal{H}(\vec{x}), \mathcal{H}(\vec{x}')] = 0 \quad \text{if} \quad |\vec{x} - \vec{x}'| > N .$$

*(locality)*

And:  $\mathcal{H}(\vec{x})$  would be bounded, so that this Hamiltonian has a *ground state (vacuum)* *(positivity)*.

In the continuum limit, this would be a *local quantum theory!*

... but the CBH series does not converge here ...

Yet, we can search for better treatments of a CA, such that *locality* and *positivity* might hold ... (see later)



# CAI

## The Cellular Automaton Interpretation of Quantum Mechanics

If the Hamiltonian of the world happens to be that of an automaton, we can identify observables called *Beables*.

*beables*  $\mathcal{B}_i(t)$  are ordinary quantum operators that happen to obey  $[\mathcal{B}_i(t), \mathcal{B}_j(t')] = 0$ .

The eigenstates of  $\mathcal{B}_i(t)$  at a given time  $t$  form a *basis*, called the ontological (ontic) basis.

# CAI

## The Cellular Automaton Interpretation of Quantum Mechanics

If the Hamiltonian of the world happens to be that of an automaton, we can identify observables called *Beables*.

*beables*  $\mathcal{B}_i(t)$  are ordinary quantum operators that happen to obey  $[\mathcal{B}_i(t), \mathcal{B}_j(t')] = 0$ .

The eigenstates of  $\mathcal{B}_i(t)$  at a given time  $t$  form a *basis*, called the ontological (ontic) basis.

In a given quantum theory, it's not known how to construct an ontic basis.

*But one can come very close ...*

The CAI *assumes* that it exists. Its ontic states can be constructed from the ordinary quantum states.

If the beables can be constructed *more or less locally* from the known states, then we have a classical, "hidden variable theory".

# The use of Templates

Hydrogen atom, plane waves of in- or out-particles, etc.

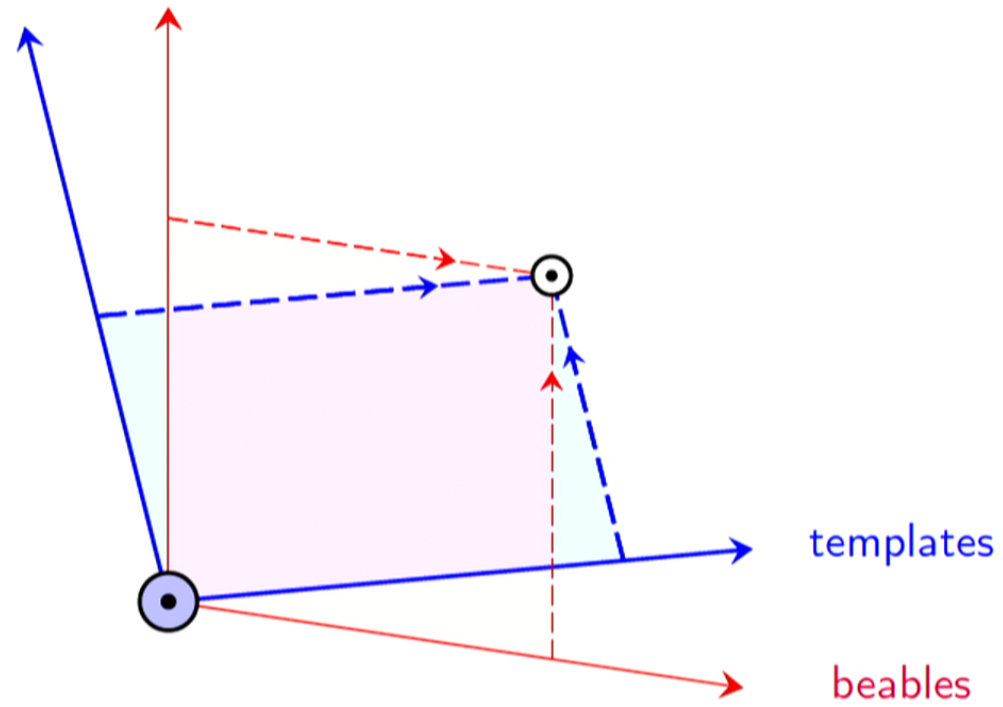



The states we normally use to do quantum mechanics are called *template states*. They form a basis of the kind normally used. This is a *unitary transformation*. Templates are quantum superpositions of *ontic states* and *vice versa*.

*They all obey Schrödinger's equation!*



The states we normally use to do quantum mechanics are called *template states*. They form a basis of the kind normally used. This is a *unitary transformation*. Templates are quantum superpositions of *ontic states* and *vice versa*.

*They all obey Schrödinger's equation!*

In a quantum calculation, we may assume the initial state to be an ontic state,  $|\psi\rangle_{\text{ont}}$ . This state will be some *superposition of template states*  $|k\rangle_{\text{template}}$ :

$$|\psi\rangle_{\text{ont}} = \sum_k \alpha_k |k\rangle_{\text{template}} \quad (1)$$

In practice, we use some given template state of our choice. It will be related to the ontic states by

$$|k\rangle_{\text{template}} = \sum_n \lambda_n |n\rangle_{\text{ont}}, \quad (2)$$

where

$|\lambda_n|^2$  are the *probabilities* that we actually have ontic state  $|n\rangle_{\text{ont}}$ .

## Classical states

How are the *classical* states related to the *ontic* states?

Imagine a *planet*. The interior is very different from the local *vacuum* state. Vacuum state has *vacuum fluctuations*.

Take  $1 \text{ mm}^3$  of matter inside the planet. Using statistics, looking at the ontic states, we may establish, with some probability,  $P(\delta V) = \varepsilon > 0$ , that the fluctuations are different from vacuum.

Combining the statistics of billions of small regions inside the planet, we can establish *with certainty* that there is a planet, by looking at the ontic state:  $1 - P(V) = (1 - \varepsilon)^{V/\delta V} = e^{-\varepsilon V/\delta V}$

## Classical states

How are the *classical* states related to the *ontic* states?

Imagine a *planet*. The interior is very different from the local *vacuum* state. Vacuum state has *vacuum fluctuations*.

Take  $1 \text{ mm}^3$  of matter inside the planet. Using statistics, looking at the ontic states, we may establish, with some probability,  $P(\delta V) = \varepsilon > 0$ , that the fluctuations are different from vacuum.

Combining the statistics of billions of small regions inside the planet, we can establish *with certainty* that there is a planet, by looking at the ontic state:  $1 - P(V) = (1 - \varepsilon)^{V/\delta V} = e^{-\varepsilon V/\delta V}$

But what holds for a planet should then be true for all classical configurations, hence:

*All classical states are ontological states!*

Classical states do not superimpose.

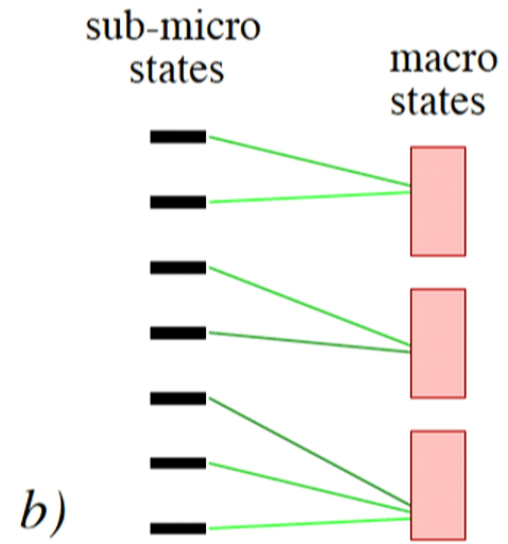
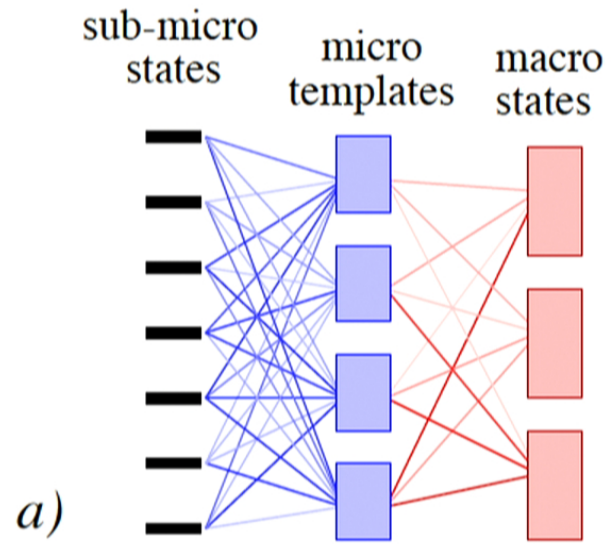

## Measurements

Paraphrase a simple “experiment”:

First, make the initial state. We take a *template* for that (such as plane in-going waves). Remember:

$$|k\rangle_{\text{template}} = \sum_n \lambda_n |n\rangle_{\text{ont}} , \quad (2)$$

Here,  $P_n = |\lambda_n|^2$ .  $\lambda_n$  are conserved in time.

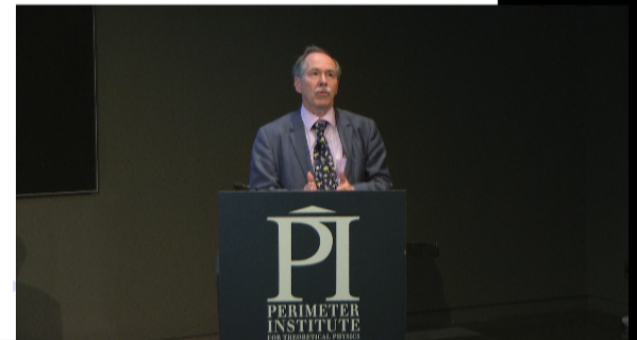

## Measurements

Paraphrase a simple “experiment”:

First, make the initial state. We take a *template* for that (such as plane in-going waves). Remember:

$$|k\rangle_{\text{template}} = \sum_n \lambda_n |n\rangle_{\text{ont}}, \quad (2)$$

Here,  $P_n = |\lambda_n|^2$ .  $\lambda_n$  are conserved in time.

Compute the final state, using Schrödinger equ. or Scattering matrix. The final state template is associated to some definite classical state. Compute

$$\text{classical}_{\text{template}} \langle \ell | k \rangle_{\text{template}} = \sum_k \lambda_n \text{classical} \langle \ell | n \rangle_{\text{ont}} \quad (3)$$



## Measurements

Paraphrase a simple “experiment”:

First, make the initial state. We take a *template* for that (such as plane in-going waves). Remember:

$$|k\rangle_{\text{template}} = \sum_n \lambda_n |n\rangle_{\text{ont}}, \quad (2)$$

Here,  $P_n = |\lambda_n|^2$ .  $\lambda_n$  are conserved in time.

Compute the final state, using Schrödinger equ. or Scattering matrix. The final state template is associated to some definite classical state. Compute

$$\text{classical}_{\text{template}} \langle \ell | k \rangle_{\text{template}} = \sum_k \lambda_n \text{classical} \langle \ell | n \rangle_{\text{ont}} \quad (3)$$

Ontic States evolve into Ontic States, and the classical states are ontological  $\rightarrow \langle \ell | n \rangle_{\text{ont}} = \delta_{kn}$ . Therefore:

$$P_n = |\lambda_n|^2 \text{ are the Born probabilities.}$$



The Born probabilities coincide with the probabilistic distributions reflecting the unknown details of the initial states.

*And that's exactly how probabilities arise in an "ordinary" classical deterministic theory.*

Ontological states form an orthonormal set: superpositions of ontological states are never ontological states themselves. The universe is in an ontological state.

*Classically*, the probabilities of the different outcomes of an experiment reflect the uncertainties in the initial state

*Quantum mechanically*, we get *the same* probabilities, but now they are the Born probabilities!

## Collapse of the Wave function

When we use a template, we find the final state to be

$$\lambda_1|k_1\rangle + \lambda_2|k_2\rangle + \dots$$

According to "Copenhagen",  $P_1 = |\lambda_1|^2$ ,  $P_2 = |\lambda_2|^2$ ,  $\dots$

Why is the final state only one of these states? Why are  $P_i$  probabilities?

The CAI gives the answer:  $|k_1\rangle$  is a possible ontic final state, and so is  $|k_2\rangle$ , but  $\lambda_1|k_1\rangle + \lambda_2|k_2\rangle$  is *not* an ontic state. That's why it never occurs in the real world.

Schrödinger's cat is ontic when it is dead, also when it is alive, but *not* when it is in a superposition.

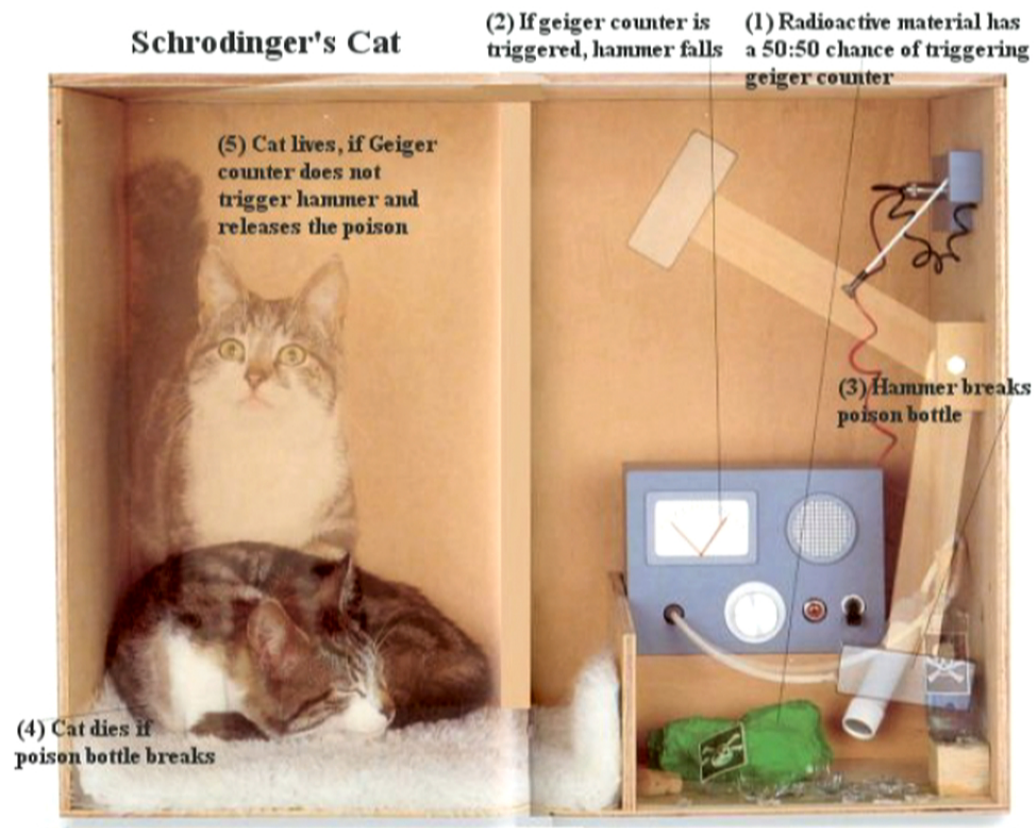

From:  
Mr. Kent's  
Chemistry  
Page



STARECAT.COM

*“About your cat, Mr. Schrödinger—I have good news and bad news.”*

## Why it is all wrong: Bell's theorem

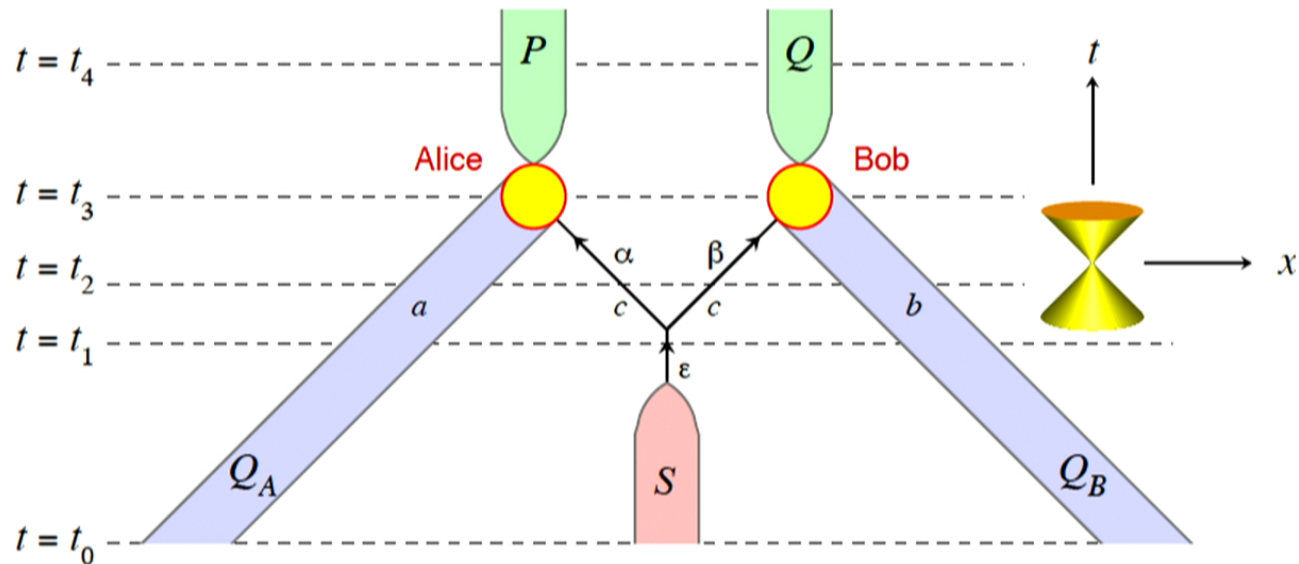

In the Bell experiment, at  $t = t_0$ , one must demand that those degrees of freedom that later force Alice and Bob to make their decisions, and the source that emits two entangled particles, need to have *3 - body correlations of the form*

(the Mousedropping Function)

But Alice and Bob have *free will*. How can their actions be correlated with what the decaying atom did, at time  $t = t_2 \ll t_3$ ?

Answer: they don't have free will: *superdeterminism*.

The Mouse-dropping argument:

But Alice and Bob have *free will*. How can their actions be correlated with what the decaying atom did, at time  $t = t_2 \ll t_3$ ?

Answer: they don't have free will: *superdeterminism*.

### The Mouse-dropping argument:

- “ Your theory is absurd. Suppose Alice and Bob both carry with them a cage, with in it a mouse.
- “ At  $t = t_1$ , an atom emits two entangled photons.
- “ At  $t = t_2 \gg t_1$  both Alice and Bob count how many droppings their mouse has produced.
- “ At  $t = t_3$ , immediately after  $t_2$ , they set their polarisation filters according to whether the number of droppings is *even* or *odd*.
- “ And now you tell me that the decaying atom already knew, in advance, how the bowels of these mice work?
- “ This is ridiculous! ”

The mouse droppings function:

$$W(a, b, c) = \frac{1}{2\pi^2} |\sin(4c - 2a - 2b)| .$$

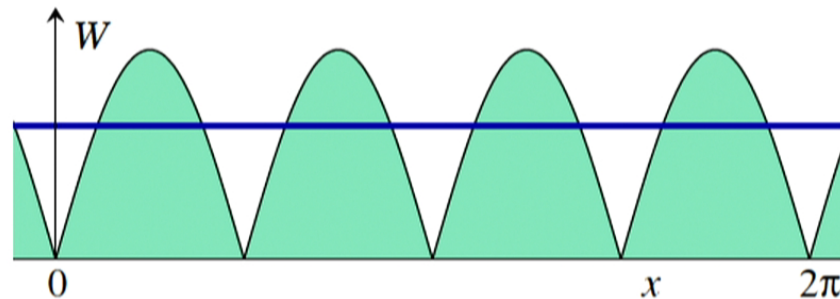

$c$  = joint polarisations entangled particles

$a$  = filter polarisation chosen by Alice

$b$  = filter polarisation chosen by Bob

$$x = 2c - a - b$$



What happened according to the CAI ?

**“Conspiracy” is ridiculous, unless there is an exact, physical, conservation law.**

We have the *ontology conservation law* :

Ontic states evolve into ontic states.

$$\text{classical}_{\text{template}} \langle \ell | k \rangle_{\text{template}} = \sum_k \lambda_n \text{classical} \langle \ell | n \rangle_{\text{ont}}$$

If Alice makes an infinitesimal modification of her settings, the *classical* state will change  $\rightarrow$  all ontic states will change:

$$\text{classical}_{\text{template}} \langle \ell + \delta\ell | k \rangle_{\text{template}} = \sum_k \lambda_m \text{classical} \langle \ell + \delta\ell | m \rangle_{\text{ont}}$$

All Alice's ontological states  $|m\rangle_{\text{ont}}$  are now different from all  $|n\rangle_{\text{ont}}$  that she had before.

The mouse droppings function:

$$W(a, b, c) = \frac{1}{2\pi^2} |\sin(4c - 2a - 2b)| .$$

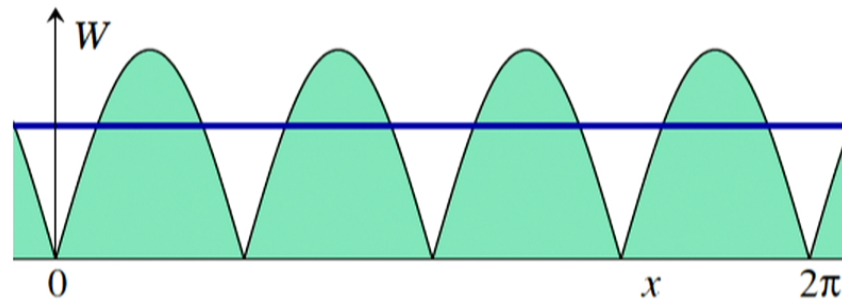

$c$  = joint polarisations entangled particles

$a$  = filter polarisation chosen by Alice

$b$  = filter polarisation chosen by Bob

$$x = 2c - a - b$$

All Alice's ontological states  $|m\rangle_{\text{ont}}$  are now different from all  $|n\rangle_{\text{ont}}$  that she had before.

So, both her past light-cone and her future light-cone are now entirely different. These light-cones do overlap with Bob's. Does this affect Bob's world, and that of the decaying atom  $S$ ?

If all ontological states had equal probabilities, the answer would be no. But one can easily imagine that some ontic states are more probable than others.

In that case, the *counterfactual* experiment  $\ell \rightarrow \ell + \delta\ell$  would lead to drastically different probabilities. *This is the way to generate non-vanishing correlation functions that disobey Bell.*

Ransom: all ontic states in the universe are associated with strong spacelike correlations. These correlations obey the ontology conservation law.

The photons  $c$  then automatically align in such a way that, after detection by Alice and Bob, they are still in an ontic state.

Same argument also applies to *single photons*:  
According to the CAI, they will be ontological regardless the  
orientation of the filter that measures their polarization.

## Conspiracy

Is this *conspiracy* ?

Same argument also applies to *single photons*:  
According to the CAI, they will be ontological regardless the orientation of the filter that measures their polarization.

## Conspiracy

Is this *conspiracy*? Not if the ontological nature of a physical state is *conserved in time*. If, at late times, a photon is observed to be in a given polarization state, it has been in *exactly the same state* from the very moment it was emitted by the source (*omniscient photons*).

*These are future-past correlations*. The conspiracy argument now demands that the “ontological basis” be *unobservable!*

Non-observable hidden variables?

“Shut up and calculate!”

## Time reversibility

The cellular automaton was constructed such that it is time reversible. The evolution operator  $U(t)$  is then a pure permutator, and its representation in Hilbert space is unitary  $\Rightarrow$

The Hamiltonian is hermitean.

Black hole physics: non time-reversibility? Let's investigate.

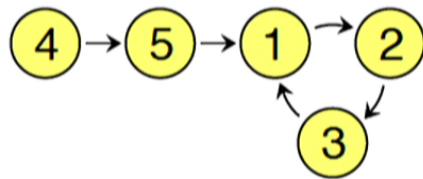

$$U(\delta t) \stackrel{?}{=} \begin{pmatrix} 0 & 0 & 1 & 0 & 1 \\ 1 & 0 & 0 & 0 & 0 \\ 0 & 1 & 0 & 0 & 0 \\ 0 & 0 & 0 & 0 & 0 \\ 0 & 0 & 0 & 1 & 0 \end{pmatrix} .$$

## Time reversibility

The cellular automaton was constructed such that it is time reversible. The evolution operator  $U(t)$  is then a pure permutator, and its representation in Hilbert space is unitary  $\Rightarrow$

The Hamiltonian is hermitean.

Black hole physics: non time-reversibility? Let's investigate.

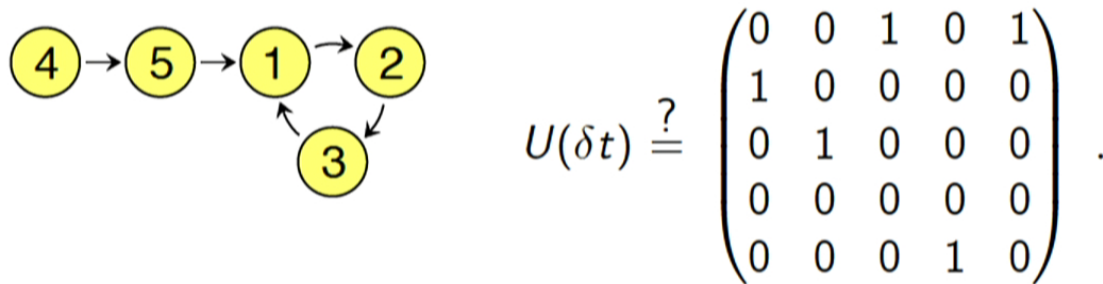

Introduce: *info-equivalence classes*:  $(5) \approx (3)$  ,  $(4) \approx (2)$

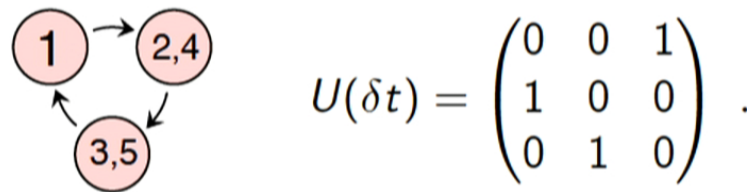

The generic, finite, deterministic, time *non* reversible model:

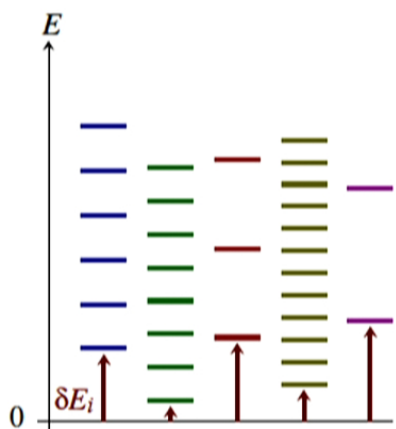
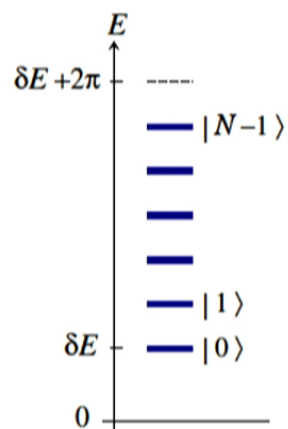
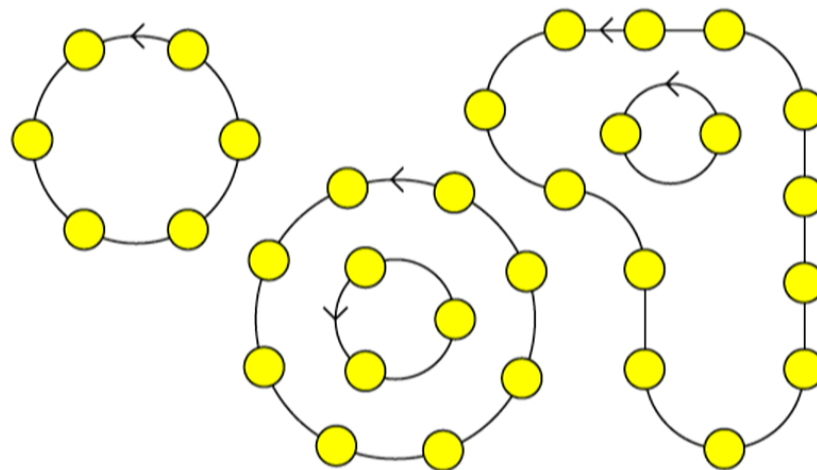



The generic, finite, deterministic, time *non*reversible model:

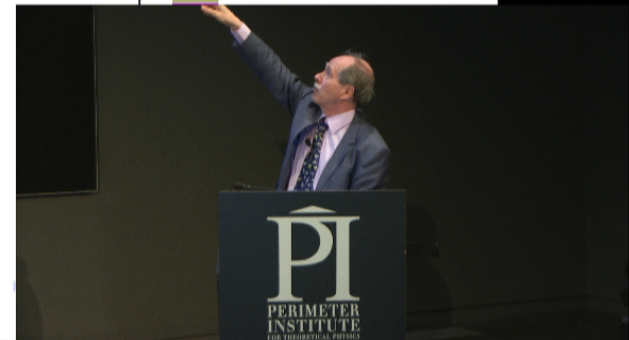
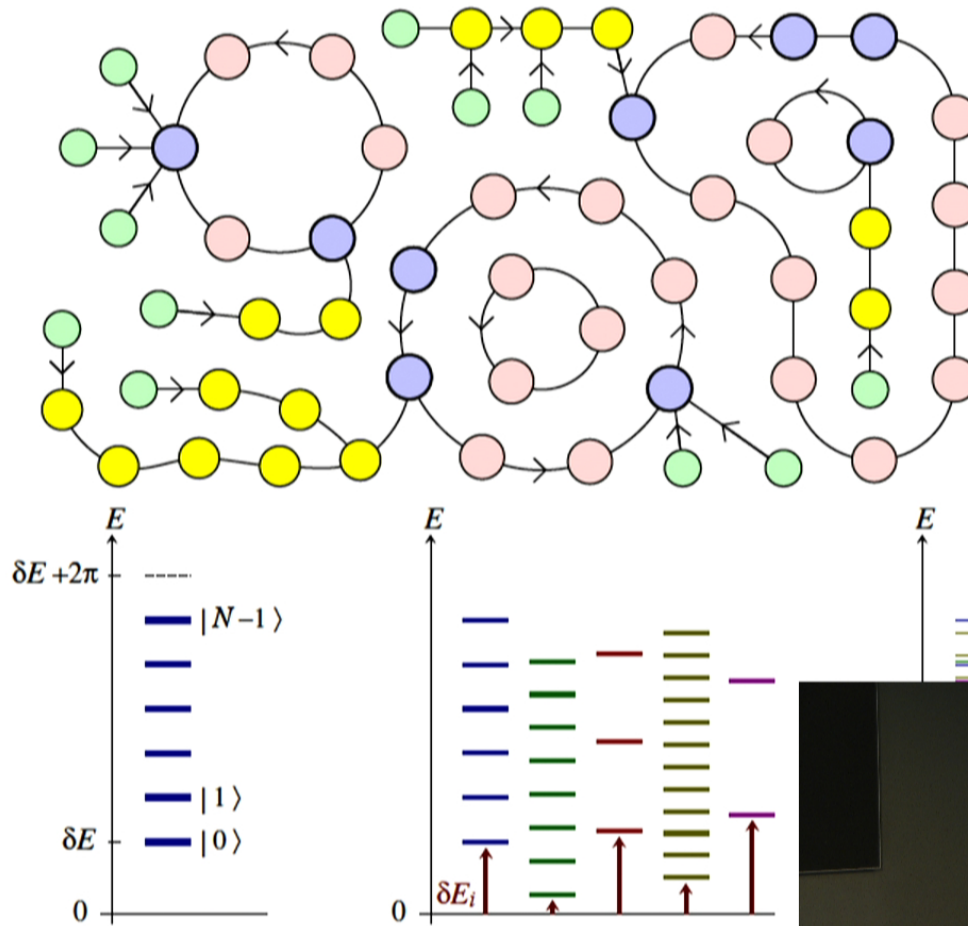

The info-equivalence classes act as local gauge equivalence classes

Maybe they *are* local gauge equivalence classes!

By construction, these equivalence classes are time-reversible.

So, *in spite of info-loss*, the quantum theory will be time-reversible:  
*PCT* invariance in QFT.

*The classical, ontological states are not time reversible!*

Therefore, the classical states carry an explicit arrow of time!

The quantum theory does not!

The info-equivalence classes act as local gauge equivalence classes

Maybe they *are* local gauge equivalence classes!

By construction, these equivalence classes are time-reversible.

So, *in spite of info-loss*, the quantum theory will be time-reversible:  
*PCT* invariance in QFT.

*The classical, ontological states are not time reversible!*

Therefore, the classical states carry an explicit arrow of time!

The quantum theory does not!



The info-equivalence classes act as local gauge equivalence classes

Maybe they *are* local gauge equivalence classes!

By construction, these equivalence classes are time-reversible.

So, *in spite of info-loss*, the quantum theory will be time-reversible:  
*PCT* invariance in QFT.

*The classical, ontological states are not time reversible!*

Therefore, the classical states carry an explicit arrow of time!

The quantum theory does not!

The generic, finite, deterministic, time *non* reversible model:

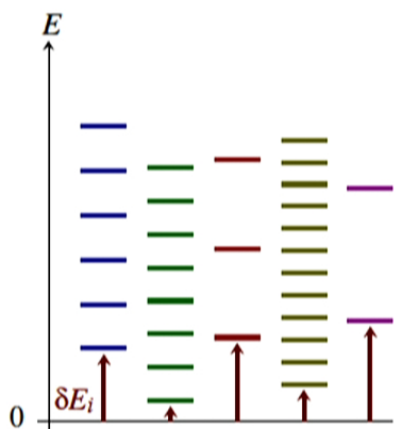
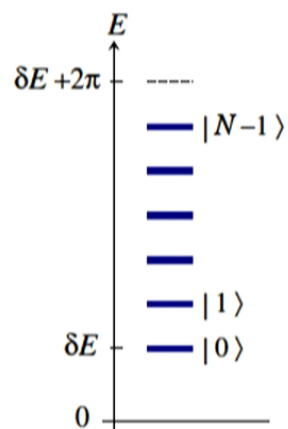
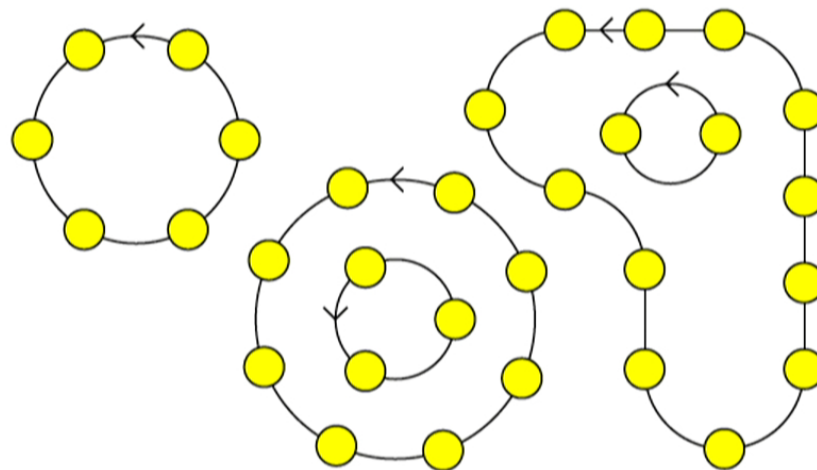

The generic, finite, deterministic, time *non*reversible model:

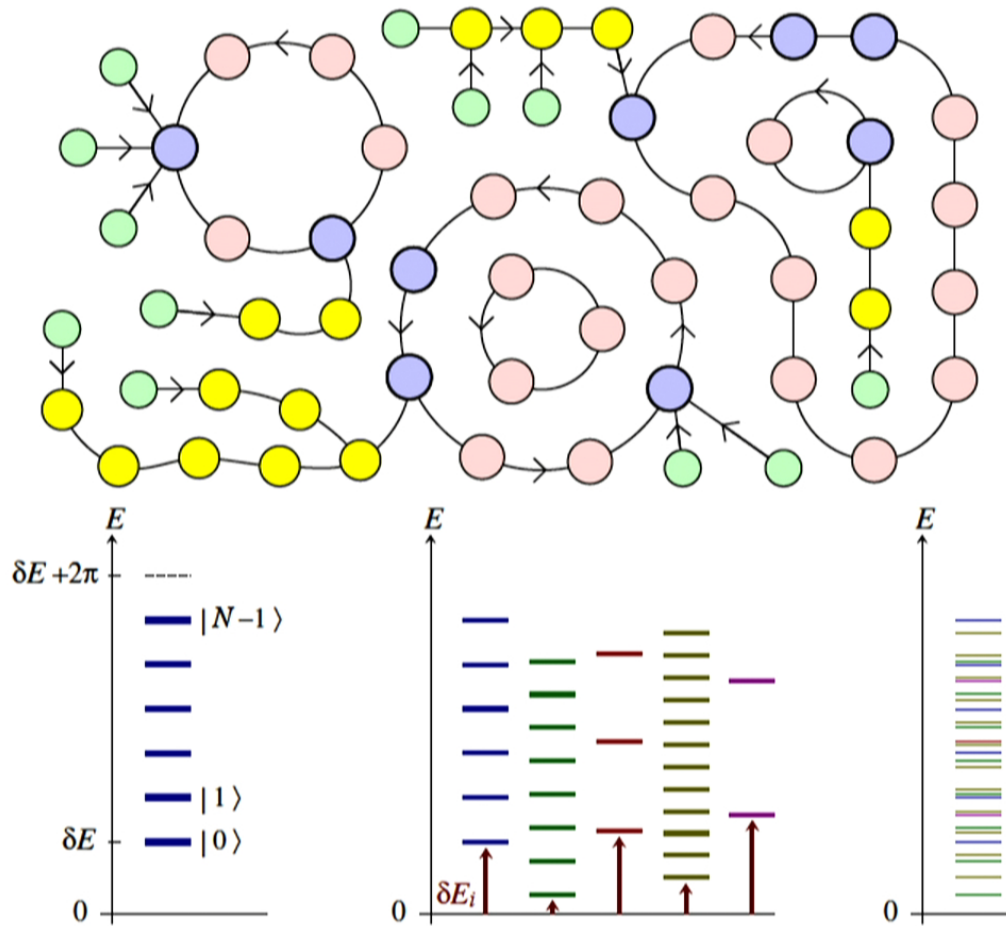

Massless, chiral, non interacting neutrinos are *deterministic*:

Second-quantised theory:  $H = -i \psi^\dagger \sigma_i \partial_i \psi$

First quantised theory:  $H = \sigma_i p_i$

$$\frac{d}{dt} \mathcal{O}(t) = i[\mathcal{O}(t), H]$$

Beables  $\{\mathcal{O}_i^{\text{op}}\} = \{\hat{p}, s, r\}$ :

$$\hat{p} \equiv \pm \vec{p}/|p|, \quad s \equiv \hat{p} \cdot \vec{\sigma}, \quad r \equiv \frac{1}{2}(\hat{p} \cdot \vec{x} + \vec{x} \cdot \hat{p}).$$

$$|\hat{p}| = 1, \quad s = \pm 1, \quad \infty < r < \infty$$

$$\frac{d}{dt} \hat{p} = 0, \quad \frac{d}{dt} s = 0, \quad \frac{d}{dt} r = s$$

These beables form a *complete set*

Massless, chiral, non interacting neutrinos are *deterministic*:

Second-quantised theory:  $H = -i \psi^\dagger \sigma_i \partial_i \psi$

First quantised theory:  $H = \sigma_i p_i$

$$\frac{d}{dt} \mathcal{O}(t) = i[\mathcal{O}(t), H]$$

Beables  $\{\mathcal{O}_i^{\text{op}}\} = \{\hat{p}, s, r\}$ :

$$\hat{p} \equiv \pm \vec{p}/|p|, \quad s \equiv \hat{p} \cdot \vec{\sigma}, \quad r \equiv \frac{1}{2}(\hat{p} \cdot \vec{x} + \vec{x} \cdot \hat{p}).$$

$$|\hat{p}| = 1, \quad s = \pm 1, \quad \infty < r < \infty$$

$$\frac{d}{dt} \hat{p} = 0, \quad \frac{d}{dt} s = 0, \quad \frac{d}{dt} r = s$$

These beables form a *complete set*

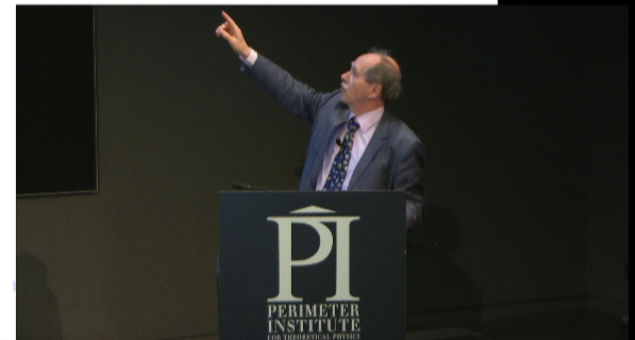



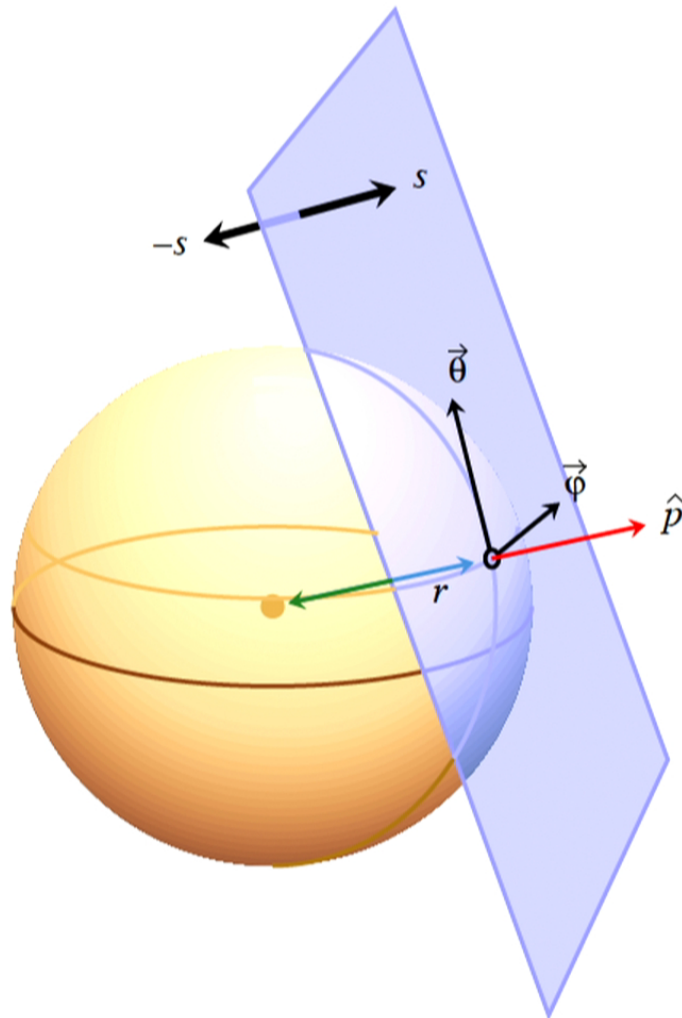

The neutrino sheet.

Beables:  $\{\hat{p}, s, r\}$

The eigenstates of these operators span the entire Hilbert space.

Introducing operators in this basis, one can reconstruct the usual operators  $\vec{x}, \vec{p}, \sigma_i$

Massless, chiral, non interacting neutrinos are *deterministic*:

Second-quantised theory:  $H = -i \psi^\dagger \sigma_i \partial_i \psi$

First quantised theory:  $H = \sigma_i p_i$

$$\frac{d}{dt} \mathcal{O}(t) = i[\mathcal{O}(t), H]$$

Beables  $\{\mathcal{O}_i^{\text{op}}\} = \{\hat{p}, s, r\}$ :

$$\hat{p} \equiv \pm \vec{p}/|p|, \quad s \equiv \hat{p} \cdot \vec{\sigma}, \quad r \equiv \frac{1}{2}(\hat{p} \cdot \vec{x} + \vec{x} \cdot \hat{p}).$$

$$|\hat{p}| = 1, \quad s = \pm 1, \quad \infty < r < \infty$$

$$\frac{d}{dt} \hat{p} = 0, \quad \frac{d}{dt} s = 0, \quad \frac{d}{dt} r = s$$

These beables form a *complete set*

Interesting mathematical physics:

$$x_i = \hat{p}_i \left( r - \frac{i}{p_r} \right) + \varepsilon_{ijk} \hat{p}_j L_k^{\text{ont}} / p_r + \frac{1}{2p_r} \left( -\varphi_i s_1 + \theta_i s_2 + \frac{\hat{p}_3}{\sqrt{1 - \hat{p}_3^2}} \varphi_i s_3 \right) \quad (1)$$

$\theta_i$  and  $\varphi_i$  are beables, functions of  $\hat{q}$ .  
 $L_k^{\text{ont}}$  are generators of rotations of the sheet,  
 $s_3 = s$ ,  $s_1$  and  $s_2$  are spin flip operators.

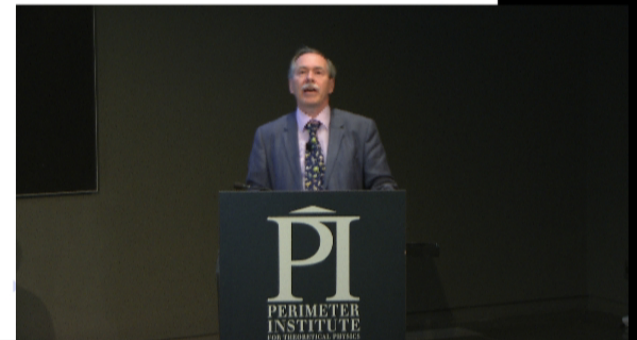

# 1<sup>st</sup> quantization

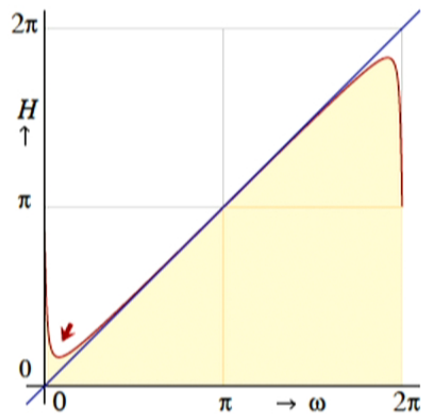
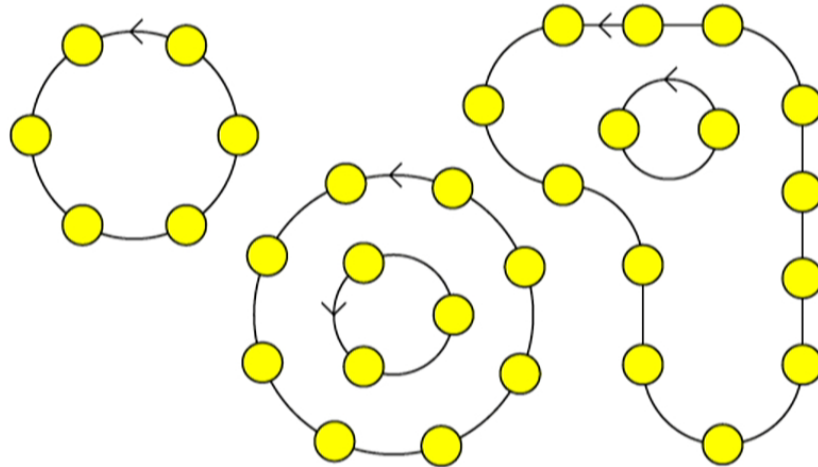

Hamiltonian with cut-off

$$H|\psi_i\rangle = h_{ij}|\psi_j\rangle$$

## 2<sup>nd</sup> quantization

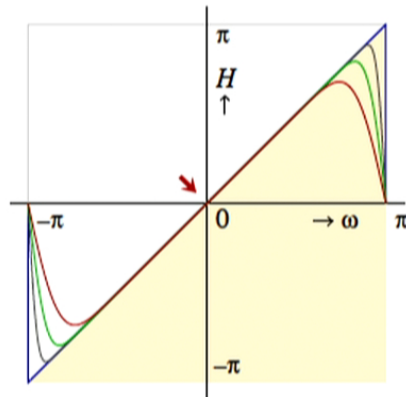
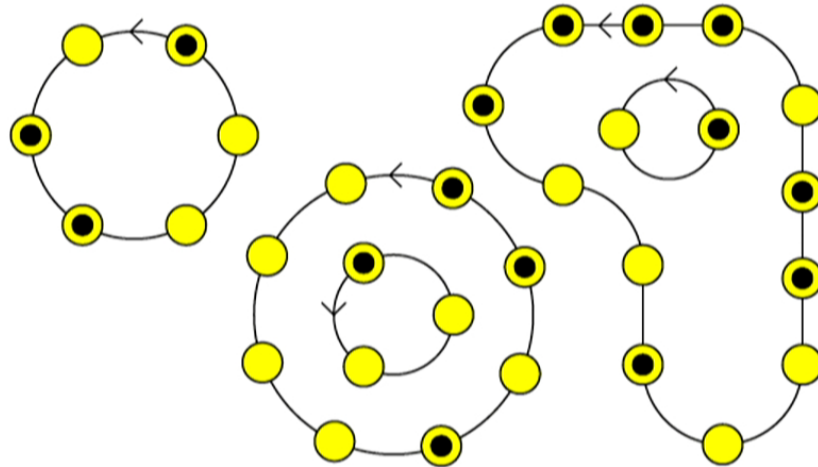

Hamiltonian with cut-off

$$H = \bar{\psi}_i h_{ij} \psi_j$$

Converges much better!

And bounded from below!

This we can do with non-interacting neutrinos, *not yet* with other fields.

Future strategy: in principle, it may be possible to construct such a theory by replacing other 1<sup>st</sup> quantized particle systems with 2<sup>nd</sup> quantized ones.

Add interactions as small corrections: perturbative QFT.

Strategy for obtaining a CA that may lead to a perturbative QFT;

Note, that perturbative QFT are not mathematically perfect, but they can serve as satisfactory descriptions of a SM for elementary particles . . .

This we can do with non-interacting neutrinos, *not yet* with other fields.

Future strategy: in principle, it may be possible to construct such a theory by replacing other 1<sup>st</sup> quantized particle systems with 2<sup>nd</sup> quantized ones.

Add interactions as small corrections: perturbative QFT.

Strategy for obtaining a CA that may lead to a perturbative QFT;

Note, that perturbative QFT are not mathematically perfect, but they can serve as satisfactory descriptions of a SM for elementary particles . . .

But conceivable, one first has to add the gravitational force . . .

Changes everything !

Gravitation as a local gauge theory for diffeomorphisms.

Could diffeomorphism classes be info equiv classes?

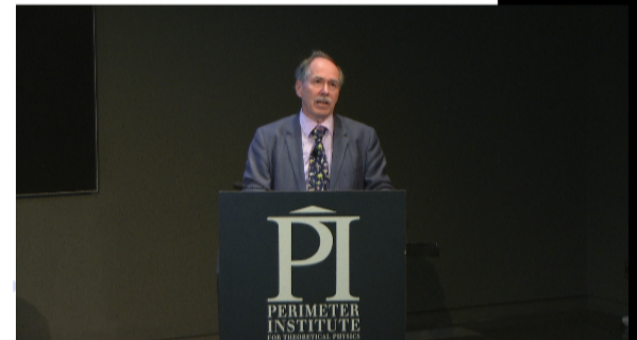



But conceivable, one first has to add the gravitational force . . .

Changes everything !

Gravitation as a local gauge theory for diffeomorphisms.

Could diffeomorphism classes be info equiv classes?

But conceivable, one first has to add the gravitational force . . .

Changes everything !

Gravitation as a local gauge theory for diffeomorphisms.

Could diffeomorphism classes be info equiv classes?

**YES!**

Such a theory may help explain why the cosm coupling const,  $\Lambda$ , is small, and why space is *globally flat* ( $k \approx 0$ ):

“The ontological theory has a flat coordinate frame”

arXiv: 1204.4926

arXiv: 1205.4107

arXiv: 1207.3612

arXiv: 1405.1548

(wait for new version)

